

Note: Due to this being copy-pasted off the website and having all of its HTML elements removed the formatting may not always be great. My apologies about that. Other than that it should all mostly check out.

1: (Q198) On a large commercial aircraft, which bus will be powered as soon as external power is connected?

- o A: The external power bus.
- o B: Battery bus.
- C: The ground handling bus.

2: (Q576) A partially blocked air filter will cause the air-driven turn indicator to:

- A: under read the correct rate of turn.
- o B: indicate zero rate of turn.
- o C: over read the correct rate of turn.

3: (Q309) What is the reason for pressurizing the hydraulic reservoirs?

- A: minimize the possibility of pump cavitation.
- o B: maintain a constant fluid level.
- o C: provide a reserve of stored energy.

4: (Q489) During the approach, a crew reads on the radio altimeter the value of 650ft. This is an indication of the true height of the...

- o A: aircraft with regard to the runway.
- B: lowest wheels with regard to the ground at any time.
- o C: aircraft with regard to the ground at a given barometric pressure.

5: (Q257) In case of a pneumatic duct leak, the crew must....

- o A: turn temperature control to full cold.
- o B: land immediately.
- C: isolate the faulty duct.

6: (Q643) With reference to a turn and bank indicator, the aircraft is in a balanced turn if:

- A: the turn is indicated and the slip is zero.
- o B: the turn pointer and slip indicator are displaced on the same side.
- o C: the turn pointer and slip indicator are zero.

7: (Q75) Radio waves travel at what speed?

- o A: Speed of sound.
- B: Speed of light.
- o C: Speed of the Earth's rotation.

8: (Q139) The sequence of entering information in a MCDU is....

- o A: IDENT - RTE - POS INIT
- B: IDENT - POS INIT - RTE
- o C: POS INIT - IDENT - RTE

9: (Q361) Is it possible to regulate the amount of oxygen from a chemical oxygen generator?

- o A: Only the crew.

- B: No.
- o C: Yes.

10: (Q16) What control surface movements will make an aircraft fitted with ruddervators yaw to the left?

- A: Left ruddervator lowered, right ruddervator raised.
- o B: Both ruddervators raised
- o C: Right ruddervator lowered, left ruddervator raised.

11: (Q712) The FMS is updated

- o A: automatically by update from the ACARS.
- o B: by the aircrew by reference to the Tech Log.
- C: by an aircraft engineer updating the system either by a floppy disc, a CD or even a hard disk.

12: (Q202) Where will you find taxi lights?

- o A: In the wing leading edges.
- o B: In the wing root.
- C: On the nose landing gear.

13: (Q233) How is in pressurized aircraft, temperature controlling mainly achieved?

- o A: Varying cabin pressure.
- o B: Adding heat to the pressurising air.
- C: Adding hot bleed air to the conditioned air.

14: (Q160) What is the nominal voltage of a NiCad battery cell?

- o A: 24 volts.
- B: 1.2 volts.
- o C: 2 volts.

15: (Q104) VHF is used by ground control facilities and aircraft or by aircraft and other aircraft on one of possible frequency channels with spacing between channels.

- o A: 2280 - 50 kHz
- o B: 360 - 8.33 kHz
- C: 720 - 25 kHz

16: (Q126) In which frequency band do VOR transmitters operate?

- A: VHF.
- o B: SHF.
- o C: UHF.

17: (Q387) An autopilot closed loop control....

- o A: has no feedback data.
- B: is controlled by the AP mode control unit.
- o C: is for stabilisation only.

18: (Q172) Which of the following systems does not use a constant speed drive?

- o A: Engine driven alternator.
- B: APU alternator.

- o C: Integrated drive generator (IDG)
- 19: (Q439) With autothrottle selected in the SPEED MODE compatible autopilot modes are
- o A: V/S and ALT ARM.
 - o B: VOR ARM and HDG HOLD.
 - C: IAS HOLD and ALT ARM.
- 20: (Q167) What determines the amount of induced voltage?
- o A: The diameter of the conductor.
 - o B: The length of the field frame.
 - C: The speed at which the conductor moves through the magnetic field.
- 21: (Q211) During normal stages of flight, the engine bleed air source comes from:
- o A: The high pressure stage of the compressor.
 - o B: Ram air.
 - C: The low pressure stage of the compressor.
- 22: (Q398) The two parameters used for category aircraft classification are....
- o A: localiser and glideslope.
 - o B: radio height/runway visual range.
 - C: decision height and runway visual range.
- 23: (Q430) The flight director is displayed on the....
- o A: EHSI
 - o B: bearing indicator
 - C: EADI
- 24: (Q127) What is the colour sequence when passing over an Outer, Middle and Inner Marker beacon?
- A: blue - amber(yellow) - white
 - o B: blue - green - white
 - o C: amber(yellow) - white - green
- 25: (Q236) The temperature within the cabin of the aircraft is normally maintained at
- o A: 12 °C to 18 °C.
 - B: 21 °C to 27 °C.
 - o C: 20 °C to 24 °C.
- 26: (Q716) Direct texts entry for airport directory or word searches on the Electronic Library System is done by ...
- o A: a keyboard underneath the active-matrix liquid display.
 - B: a soft keyboard function, displayed on the liquid display screen.
 - o C: the scratch pad on the CDU.
- 27: (Q6) When ailerons are deployed, what happens to the drag? Drag increases on....
- o A: both wings.
 - B: the up going wing.
 - o C: the down going wing.

28: (Q521) Emergency lightning can be illuminated by....

- o A: automatically when power is removed from the aircraft (in an emergency or by the pilots).
- o B: a guarded three position switch (ON-OFF-ARMED) in the cabin and a Two position switch in the cockpit (ON-NORMAL).
- C: a guarded three position switch (ON-OFF-ARMED) in the cockpit and a Two position switch in the cabin (ON-NORMAL).

29: (Q713) Which system provides airline flight, maintenance, and cabin crews with instantaneous access to operational manuals, procedures and navigation charts?

- o A: OMS (Onboard Maintenance System).
- B: ELS (Electronic Library System).
- o C: FMS (Flight Management System).

30: (Q49) What is the result of moving the helicopter forward?

- A: advancing blade flapping up.
- o B: retreating blade flapping up.
- o C: pitch angle of all blades decreasing.

31: (Q39) What happens to the drag, when the angle of attack is increased on a main rotor blade?

- o A: there is no change in drag.
- B: there is an increase in drag.
- o C: there is a reduction in drag.

32: (Q78) If a wave has a velocity of 4800 meter per second and a wave-length of 5 meter, what is the frequency of the wave?

- o A: 9,6 kHz
- B: 960 Hz
- o C: 0,96 MHz

33: (Q730) Which LRU is the interface between the aircraft systems and the ARINC network remote switches and convert network data to the appropriate format.

- A: Remote Data Concentrators.
- o B: ARINC 664 remote switches.
- o C: AFDX switches.

34: (Q752) The external communication (IFE) system provides communication with the aircraft while grounded through ...

- o A: a cell modem component and an antenna located in the aircraft.
- o B: an ethernet connection in the aircraft.
- C: a cell modem component and a terminal receiving station..

35: (Q20) The purpose of a spring tab is to....

- o A: provide feel back in a control system.
- B: provide a reduction in the pilot's effort to move the controls against high air loads.
- o C: provide a constant load resistance to surface deflection at all speeds.

36: (Q714) Information updates to the airborne system and communications between the ground based and airborne systems are accomplished ...

- o A: by an aircraft engineer updating the system either by a floppy disc, a CD or even a hard disk.
- o B: automatically by update from the ECAM.
- C: through the Gate-link concept.

37: (Q778) What are the reasons for automatic deployment of emergency oxygen? 1. Cabin depressurization. 2. Smoke in the cabin. 3. Insufficient cabin air in-flow.

- o A: 1 + 2
- o B: 1 + 2 + 3
- C: 1 + 3

38: (Q43) How does collective control input affect the pitch of the blades?

- o A: increases the angle on the retreating blade and reduces it on the advancing one.
- B: increases the pitch angle the same amount on all blades.
- o C: increases the angle on the advancing blade and reduces it on the retreating one.

39: (Q515) What is the difference between VOR and hyperbolic navigation?

- A: VOR has straight lines and hyperbolic navigation lines are curved.
- o B: Hyperbolic has straight radial lines and VOR navigation lines are curved.
- o C: There is no difference between VOR and Hyperbolic navigation.

40: (Q259) What type of fire detection system is a fenwal detection system?

- o A: Spot system.
- o B: Thermocouple system.
- C: Continuous loop system.

41: (Q747) Which discretes provides the PSEU (Proximity Switch Electronics Unit) to the IFES SC (In-Flight Entertainment System Controller)?

- A: Air/ground discrete; parking brake discrete; start take-off roll discrete; nose landing gear discrete.
- o B: Air/ground discrete; air speed discrete; altitude discrete, GPS position discrete.
- o C: Air/ground discrete; IRS (Inertial Reference System) position discrete; ADC (Air Data Computer) discretes (Airspeed, Ground speed, Mach number, altitude).

42: (Q112) New ELT s will transmit on so that the signal can be picked up by the Search and Rescue satellite network.

- A: 406.025 MHz
- o B: 108.10 MHz
- o C: 121.5 MHz

43: (Q445) The purpose of Auto Throttle is:

- o A: automatic shut down of one engine at too high temperature.
- B: to maintain constant engine power or airplane speed.
- o C: to deactivate manual throttles and transfer engine control to Auto Pilot

44: (Q57) What is a Fuselage body Station?

- A: longitudinal point on the fuselage.
- o B: lateral point on the fuselage.
- o C: lateral point on a wing.

45: (Q320) When a hydraulic lock condition in a jack occurs, what happens to the hydraulic flow?

o A: no flow, but jack continues to move under gravity.

• B: no flow, jack is stationary.

o C: flow, but no movement.

46: (Q715) An Electronic Library System consists of : 1. a LCD. 2. an optical disk drive. 3. a printer. 4. a workstation platform. 5. capacitive touch screen overlay. 6. A keyboard.

o A: 1, 3, 4 and 5.

o B: 1, 2, 3 and 6.

• C: 1, 2, 3, 4 and 5.

47: (Q383) A single axis autopilot may also be called:

o A: auto stabilisation loop.

• B: wing leveller.

o C: altitude hold.

48: (Q33) What is autorotation?

o A: spinning of the helicopter fuselage due to the loss of anti-torque.

• B: descent of the helicopter with power off.

o C: loss off directional control.

49: (Q742) The ARINC 664 Ethernet uses ...

o A: a pair of twisted wires with shielding around them for full duplex operation at 2 megahertz.

• B: two twisted wire pairs or quad cables as the transport medium for full duplex operation at 100 megabits per second.

o C: a high speed, two way, multiple terminal digital data bus operating at 2 megahertz.

50: (Q688) In a modern airplane equipped with an ECAM (Electronic centralized aircraft monitor), when a failure occurs in a circuit, the centralized flight management system: 1. releases an aural warning. 2. lights up the appropriate push-buttons on the overhead panel. 3. displays the relevant circuit on the system display. 4. processes the failure automatically. The combination regrouping all the correct statements is:

• A: 1, 2 and 3.

o B: 3 and 4.

o C: 1, 3 and 4.

51: (Q704) The Head Up Display (HUD) is a device allowing the pilot, while still looking outside, to have:

o A: a monitoring only during Cat III precision approaches.

• B: a synthetic view of the instrument procedure.

o C: a navigating control aid.

52: (Q658) A flux valve senses the changes in orientation of the horizontal component of the earth's magnetic field. 1. The flux valve is made of a pair of soft iron bars. 2. The primary coils are fed AC voltage (usually 487.5 Hz). 3. The information can be used by a 'flux gate' compass or a directional gyro. 4. The flux gate valve casing is dependent on the aircraft three inertial axis. 5. The accuracy on the value of the magnetic field indication is less than 0.5 %. Which of the following combinations contains all of the correct statements?

o A: 1, 3, 4, 5.

- o B: 1, 4, 5.
- C: 2, 3, 5.

53: (Q732) The first 2 bytes of the IP address for IMA communication are called ...

- A: the Net ID.
- o B: Host ID.
- o C: Sign Status Matrix (SSM).

54: (Q158) The satellites (GPS) provide: position, time data and....

- o A: distance from departure.
- o B: flightplan.
- C: velocity.

55: (Q680) This amber symbol appears in place of the normal altitude display when: (See the figure)



- o A: the radio altitude needs re-setting on the EHSI.
- B: there is a failure of the radio altimeter.
- o C: the selected radio altitude has been reached.

56: (Q678) Identify the correct statement (See the figure)

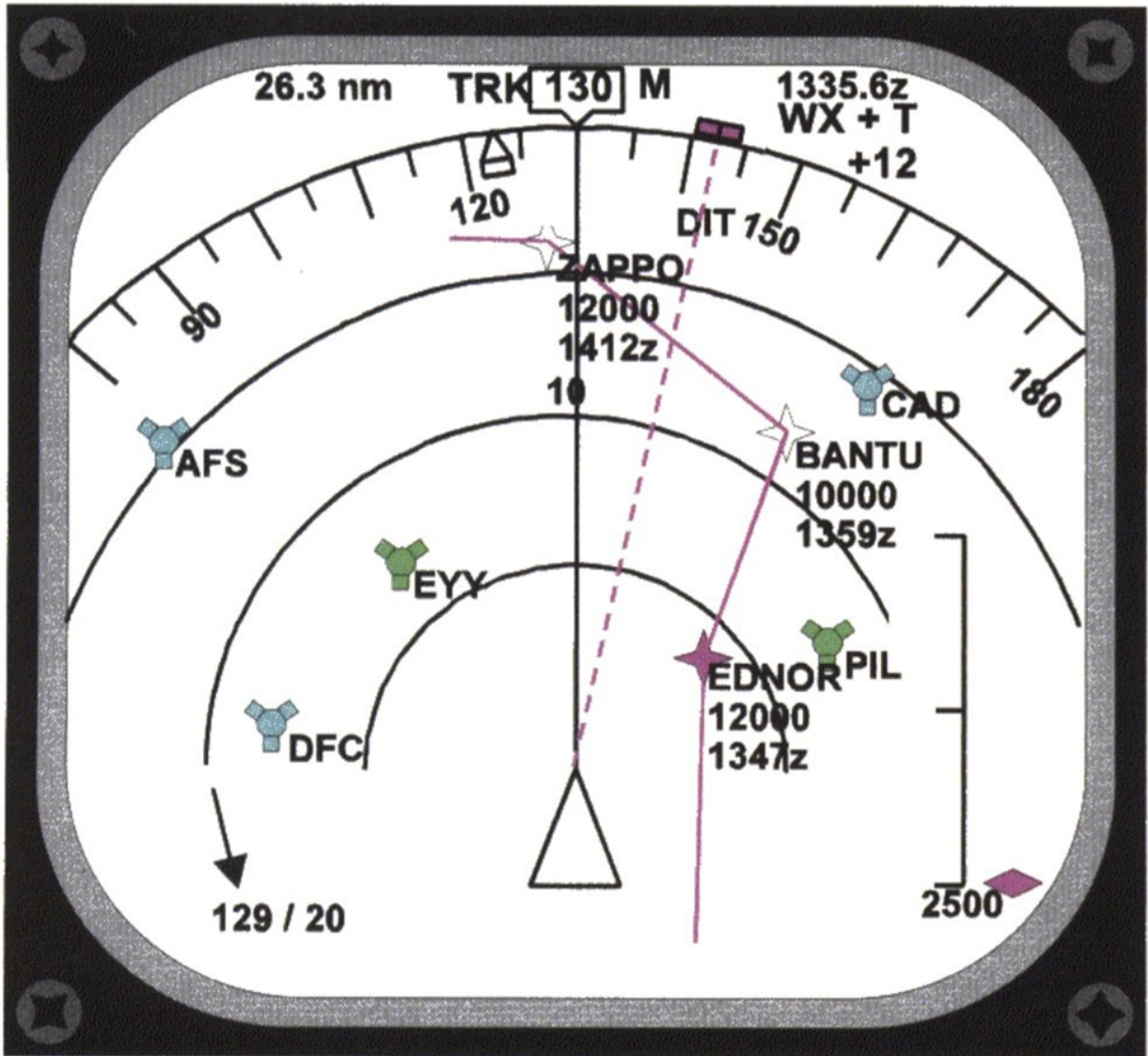

- o A: When established on the localiser the inbound heading will be 165°M.
- o B: The aircraft's track is 165°M.
- C: The aircraft is closing the localiser from the right, heading 130°M and is approaching the glide path from above.

57: (Q349) A nose wheel steering control system....

- o A: prevents the nosewheel from castering at all times.
- B: allows the nosewheel to caster within preset limits when in the neutral position.
- o C: allows the nosewheel to caster freely at all times.

58: (Q675) Where in the aircraft should the FDR be fitted according to the EASA regulations?

- o A: In the wings.
- o B: In the nose landing gear bay.
- C: At the rear of the aircraft.

59: (Q303) What is the purpose of a check valve?

- o A: prevents pump cavitation.
- B: allows fluid to flow only in one direction.
- o C: prevents overpressure.

60: (Q170) What type of voltage regulator is shown in the figure below?

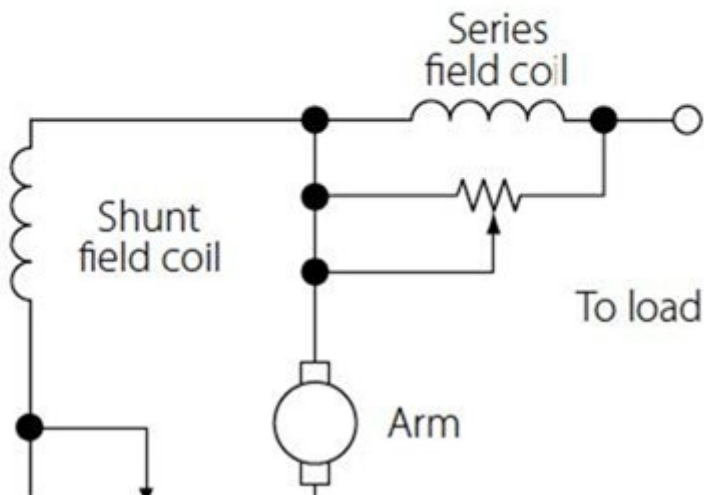
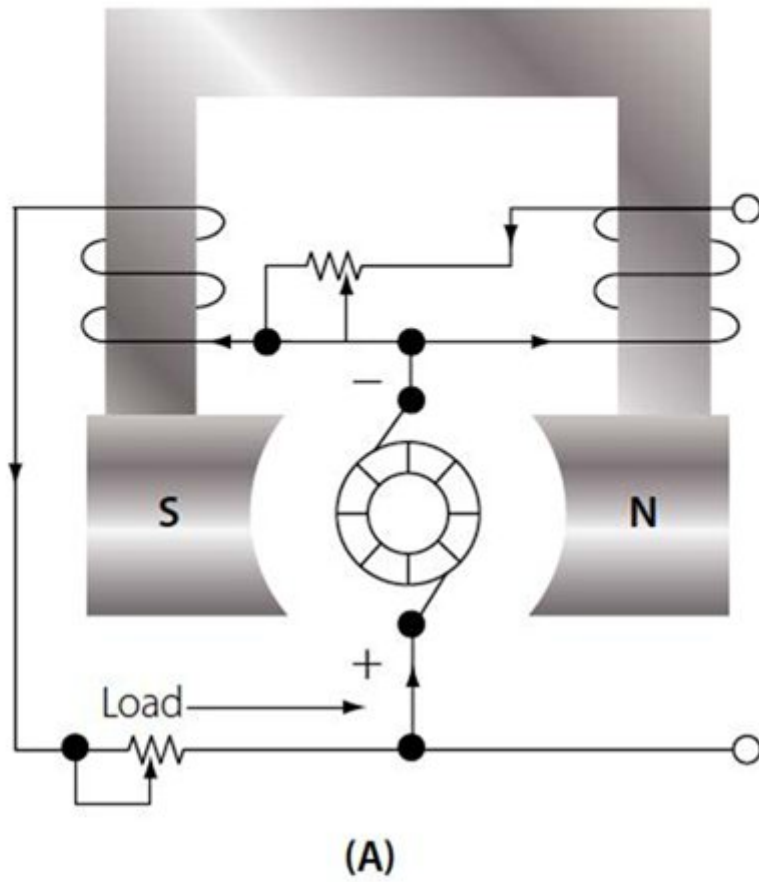

- o A: Parallel wound generator.
- o B: Series wound generator.
- C: Compound wound generator.

61: (Q161) Which is the most efficient way of charging a battery?

- o A: Both slow and fast are equally efficient
- B: Fast
- o C: Slow

62: (Q656) The purpose of the slaving torque motor is:

- A: To produce a precessive force in order to align the gyro with the earth's magnetic field.
- o B: To ensure that the gyro wheel maintains sufficient speed to stay rigid in space.
- o C: To send heading information to the compass card in the heading indicator.

63: (Q561) Density varies:

- A: directly with pressure and inversely with temperature.
- o B: inversely with pressure and directly with temperature.
- o C: directly with temperature and pressure.

64: (Q721) Helicopter rotor track and balance is done by

- A: the 'HUMS' (Health and Usage Monitoring System).
- o B: the 'Damage Tolerance Monitoring System'.
- o C: the 'Low Cycle Fatigue Counter'.

65: (Q128) Transmissions from VOR facilities may be adversely affected by....

- A: uneven propagation over irregular ground surfaces.
- o B: night effect.
- o C: static interference.

66: (Q770) What will be shown when the fault tolerant system has a fault but has not generated a caution or a warning on the flight deck?

- o A: A specific status message.
- B: A maintenance memo.
- o C: A scheduled fault message.

67: (Q604) An encoding altimeter is a....

- A: pneumatic altimeter that sends a digital code to the ATC transponder.
- o B: full digital altimeter.
- o C: combined altimeter and airspeed indicator.

68: (Q540) Active load control involves....

- o A: intervention & monitoring the human pilot.
- o B: limiting the deflection of control surface with airspeed.
- C: operating control surfaces in an unconventional manner.

69: (Q89) For hf-radio communications covering long distances, what is the most important layer of the ionosphere?

- A: F

- o B: C
- o C: D

70: (Q773) Which communication system let the flight crew request and obtain information about meteorological parameters (weather, wind, visibility, clouds,.....)?

- A: ATIS (Automatic Terminal Information System).
- o B: FANS (Future Air Navigation Systems).
- o C: Automatic Dependent Surveillance Broadcast

71: (Q644) The rate gyro indicates the correct rate of turn when the ..(1).... precession due to the spring is ..(2)..... to the ..(3)..... force.

- A: (1) secondary - (2) equal - (3) primary applied.
- o B: (1) secondary - (2) opposite - (3) primary precessed.
- o C: (1) torqued - (2) opposite - (3) primary precessed.

72: (Q243) The standard cabin pressure during flight on civil airliners is....

- o A: is equal to the air pressure on 15000 feet.
- B: is equal to the air pressure on 8000 feet.
- o C: maintained on ground level conditions.

73: (Q149) To carry out FMS database update on FMS

- o A: insert new data on CDU.
- B: use database loader.
- o C: insert new EPROM.

74: (Q380) The command bars of a flight director are generally represented on an:

- A: ADI (Attitude Director Indicator).
- o B: HSI (Horizontal Situation Indicator).
- o C: RMI (Radio Magnetic Indicator).

75: (Q207) Which statement is true?

- o A: Operating the internal emergency light switch only turns on the internal emergency lights.
- o B: When operating the external emergency light switch both internal and external lights come on.
- C: When the internal emergency light switch is used both internal and external emergency light come on.

76: (Q660) The Ground Proximity Warning systems mode 2 is activated when

- o A: An excessive height loss is experienced after take-off during go-around.
- B: The aircraft is flying into rising terrain.
- o C: The barometric descent rate is excessive with respect to the aircraft height above the terrain.

77: (Q168) How do you call the component that completes the magnetic circuit between the poles in a DC generator?

- o A: The brushes.
- o B: The armature.
- C: The yoke.

78: (Q129) In a Doppler VOR (DVOR) the reference signal is ... (1) ..., the bearing signal is ... (2) ... and the direction of rotation of the bearing signal is ... (3) ...

- A: (1) AM - (2) FM - (3) anti-clockwise.
- o B: (1) AM - (2) FM - (3) clockwise.
- o C: (1) FM - (2) AM - (3) clockwise.

79: (Q68) What causes the glow which can be seen during the initial stage of a lightning strike?

- A: Ionization of the air.
- o B: Static discharging.
- o C: Burning of metal.

80: (Q292) In a fuel system with interconnected vents ...

- o A: an expansion space is not required.
- B: the expansion space must be 2 % of the tank capacity.
- o C: the expansion space must be 10 % of the tank capacity.

81: (Q278) During a fire bottle squib test, the green light illuminates. This indicates:

- A: That the squib and firing circuits are OK.
- o B: That the squib has fired.
- o C: That the squib is good.

82: (Q685) Mode available for (EFIS) HSI on some units are:

- A: MAP and PLAN.
- o B: Airspeed and Mach.
- o C: VOR, ILS, MAP and AUTO TRIM.

83: (Q552) In a direct cable control system, what happens to the forces the pilot feels if airspeed increases?

- o A: Remain the same.
- o B: Decrease.
- C: Increase.

84: (Q665) If the GPWS (Ground Proximity Warning System) activates, and alerts the pilot with an aural warning 'DON'T SINK' (two times), it is because:

- o A: the aircraft experiences an unexpected proximity to terrain, without landing-flap selected.
- B: during take-off or missed approach maneuver, the aircraft has started to lose altitude.
- o C: the aircraft experiences an unexpected proximity to the terrain, with landing gear retracted.

85: (Q482) What does the Radar contour button do?

- o A: Alter the video amplifier.
- o B: Alter the transmitter power.
- C: Alter the display presentation.

86: (Q106) Satisfactory two-way VHF communication can typically be maintained up to miles, this range dependent on the aircraft height.

- A: 200
- o B: 20
- o C: 2000

87: (Q572) What will result if the instrument static pressure line becomes disconnected inside a pressurized cabin during cruise flight?

- A: The altimeter and airspeed indicator will both read low.
- o B: The altimeter and airspeed indicator will both read high.
- o C: The altimeter will read low and the airspeed indicator will read high.

88: (Q616) A direct reading aircraft thermometer usually consists of a bimetallic helix protruding into the airstream. Movement of the pointer over the temperature scale will depend upon:

- o A: difference in electrical resistance of the two metals.
- o B: increase in pressure as airspeed increases.
- C: different coefficients of expansion of the two metals.

89: (Q120) What is the glide slope frequency range?

- A: 329 - 335 Mhz.
- o B: 108 - 112 Ghz.
- o C: 108 - 112 Mhz.

90: (Q272) Where is the lavatory waste bin fire extinguisher localized?

- o A: In lavatory ceiling.
- o B: There is no extinguisher in the lavatory.
- C: Is usually located above the waste bin.

91: (Q302) In an open-centre hydraulic system, selector valves are positioned ...

- o A: in parallel.
- B: in series.
- o C: either in series or parallel depending on the system design.

92: (Q408) The purpose of a yaw damper is to

- o A: produce a coordinated turn.
- o B: assist the aerodynamic response.
- C: block the Dutch roll frequency.

93: (Q571) True airspeed is....

- o A: equal to dynamic pressure minus static pressure.
- B: dependent on the air density.
- o C: the pressure caused by the forward movement of the aircraft.

94: (Q428) Central Air Data Computers (CADC's) transmit data concerning

- o A: airspeed, altitude and decision height.
- o B: airspeed and altitude only.
- C: airspeed, altitude and Mach number.

95: (Q531) How can adverse yaw when rolling about the longitudinal axis may be prevented?

- A: Differential ailerons.
- o B: A smaller fin.
- o C: Equal deflection lateral control surfaces.

96: (Q402) During approach, roll out mode occurs....

- o A: at alert height.
- o B: before flare.
- C: after flare.

97: (Q759) Which item handles all of the on-demand applications available to passengers?

- o A: the IFES Crew Panel.
- o B: the IFES Advanced Master Control Unit (AMCU).
- C: the IFES File Server.

98: (Q698) Angle of attack may be sensed by means of ...(1) ...mounted ...(2)...

- o A: (1) a stick pusher - (2) adjacent to the flying controls.
- B: (1) a hinged vane sensor - (2) on the wing leading edge.
- o C: (1) a conical slotted probe - (2) on the wing leading edge.

99: (Q194) What type of transformer is shown in the figure below?

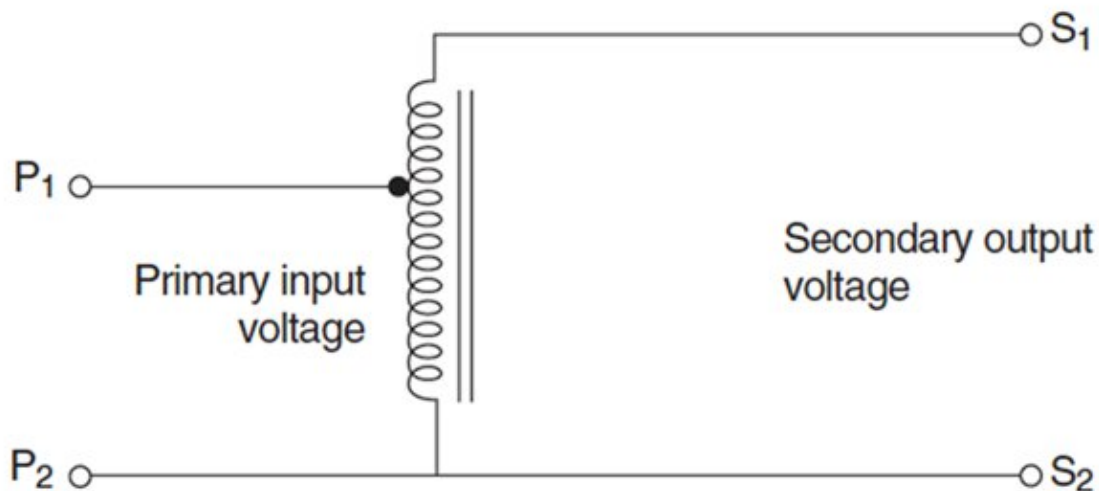

- A: Autotransformer
- o B: Transformer rectifier.
- o C: Current transformer

100: (Q444) During the flair mode the A/T throttle will

- o A: disconnect autothrottle.
- o B: select reverse thrust.
- C: retard throttle to idle.

101: (Q737) Airplane system data critical to flight are connected to the..... In the Core Network System.

- o A: Open Data Network (ODN).
- B: Isolated Data Network (IDN).
- o C: Common Data Network (CDN).

102: (Q706) One of the advantages of the OMS (Onboard Maintenance System) is ...

- o A: to replace the tech log.
- B: to detect and report failure.
- o C: to help the pilots do a minor maintenance task.

103: (Q451) In a duplex system, the detection of a failure of one simplex system will disconnect...

- o A: the failed system and carry on with an autoland.
- B: the failed system and continue in a trimmed safe attitude.
- o C: all channels.

104: (Q235) What must be the minimum humidity in the cabin?

- A: 30 %.
- o B: 20 %.
- o C: 60 %.

105: (Q249) During the take-off mode the outflow valves are in the pre-pressurisation position. How do the outflow valves move?

- o A: In the modulating mode.
- o B: Move to open position.
- C: Move towards closed.

106: (Q397) If go-around has been initiated after auto-land has been selected, the aeroplane will

- A: increase speed and rotate nose up.
- o B: increase speed.
- o C: rotate nose up.

107: (Q526) Which priority do announcements from the flight deck have?

- o A: Priority 5.
- B: Priority 1.
- o C: Priority 2.

108: (Q18) What is the effect of a Fowler flap on the wing?

- A: increases camber and wing area.
- o B: increases camber only.
- o C: increases wing area only.

109: (Q324) A serrated rotor ice detector provides warning of ice by ...

- o A: decreased torque caused by ice formation slowing the rotating wheel and illuminating a warning light in the cockpit.
- o B: ice formation stopping the rotation of a rotary knife edge and illuminating a warning light in the cockpit.
- C: increased torque caused by ice formation slowing the rotating wheel and illuminating a warning light in the cockpit.

110: (Q103) The VHF (very high frequency) is the standard civil short range communication facility using the band of frequencies between

- o A: 2 and 29.999 MHz.
- o B: 1.5 to 1.6 GHz.
- C: 118 and 136 MHz.

111: (Q40) What is the ability of the rotor blade to move up and down called?

- A: flapping.
- o B: dragging.
- o C: feathering.

112: (Q330) What must you be aware of when testing pitot head heaters?

- o A: They can only be checked by noting the rate of temperature rise of the probe.
- o B: They should be switched on for five minutes to allow to stabilise before taking ammeter readings.
- C: They must only be switched on for the minimum time required to check serviceability.

113: (Q318) Throttling valves in a hydraulic system are used to ...

- o A: limit the maximum pressure.
- o B: restrict the rate of pressure build up.
- C: control the flow rate of system operation.

114: (Q97) Energy is transmitted from a transmitter into space using which of the following devices?

- o A: a delay time.
- o B: a receiver.
- C: an antenna.

115: (Q145) If there is no (navigation) radio updating, what effect will this have on the FMS?

- o A: this FMS will automatically update the system.
- o B: this will have no effect on the FMS.
- C: this may cause the FMS to deviate from the desired track.

116: (Q420) Automatic mach trim is functional in the....

- A: pitch channel only with the autopilot engaged.
- o B: pitch and roll channel with the autopilot engaged.
- o C: pitch channel only with the autopilot disengaged.

117: (Q702) A vibration meter measures the....

- o A: period in seconds.
- B: amplitude at a given frequency.
- o C: frequency in Hz.

118: (Q72) For a frequency of 121.95 MHz, what is the wavelength?

- o A: 2.46 cm
- B: 2.46 m
- o C: 2.46 km

119: (Q455) The order of autoland approach is

- o A: LOC, GS, FLARE, ATT HOLD
- B: LOC, GS, ATT HOLD, FLARE
- o C: GS, LOC, ATT HOLD, FLARE

120: (Q305) Accumulators as fitted to aircraft hydraulic systems ...

- o A: provide additional fluid if leaks occur.

- o B: are only ever used in an emergency.
 - C: store fluid under pressure.
- 121: (Q41) How do the rotors turn on a co-axial rotor system?
- o A: They counter-rotate on separate masts.
 - B: They counter-rotate on a common shaft.
 - o C: Both rotate in the same direction on a common shaft.
- 122: (Q416) Automatic trim is used to....
- o A: prevent loads on the elevator trims.
 - o B: allow full authority to be regained by the aileron.
 - C: maintain level flight.
- 123: (Q304) What is the function of a thermal relief valve in an hydraulic system?
- o A: prevent a leak back of pressure.
 - B: relieve excess pressure.
 - o C: prevent excess temperature.
- 124: (Q356) What is the chemical used in chemical oxygen generators?
- A: Sodium chlorate and iron
 - o B: Sodium hydroxide
 - o C: Ozone
- 125: (Q425) When the altitude select mode is engaged on a jet transport airplane equipped with autopilot (AP) and auto-throttle (ATS) systems the....
- o A: calibrated airspeed (CAS) is maintained constant by the autopilot by means of elevator.
 - o B: true airspeed (TAS) is maintained constant by the auto-throttle system.
 - C: indicated airspeed (IAS) is maintained constant by the autopilot by means of elevator.
- 126: (Q479) A mode C transponder
- o A: can be used for TCAS II.
 - o B: can be used for TCAS on ILS approach only.
 - C: cannot be used for TCAS II.
- 127: (Q686) An EFIS, having a control panel, symbol generators and a remote light sensor, also has:
- o A: EADIs and WXR displays.
 - o B: EADIs and EICAS.
 - C: EADIs and EHSIs.
- 128: (Q277) Why is there a strainer installed in the fire bottle discharge valve?
- o A: To catch any fragment from the bottle.
 - o B: To catch the yellow disk as an indication that the fire bottle is used.
 - C: To catch any fragment from the frangible disk.
- 129: (Q300) In case of a CG control system failure, the computer switches automatically to an alternate mode. What will happen?
- o A: jettison of the fuel in the trim tank.
 - o B: stops fuel transfer from or to the trim tank.

- C: the trim tank will be directly used to feed the engines..

130: (Q495) The ADS-B (Automatic Dependent Surveillance Broadcast) digitises the position information derived from....and broadcasts it as part of a data stream.

- o A: INS or IRS.
- B: GNSS.
- o C: R-NAV system.

131: (Q756) The information signs are controlled from the cabin configuration software inside the....
(See the figure)

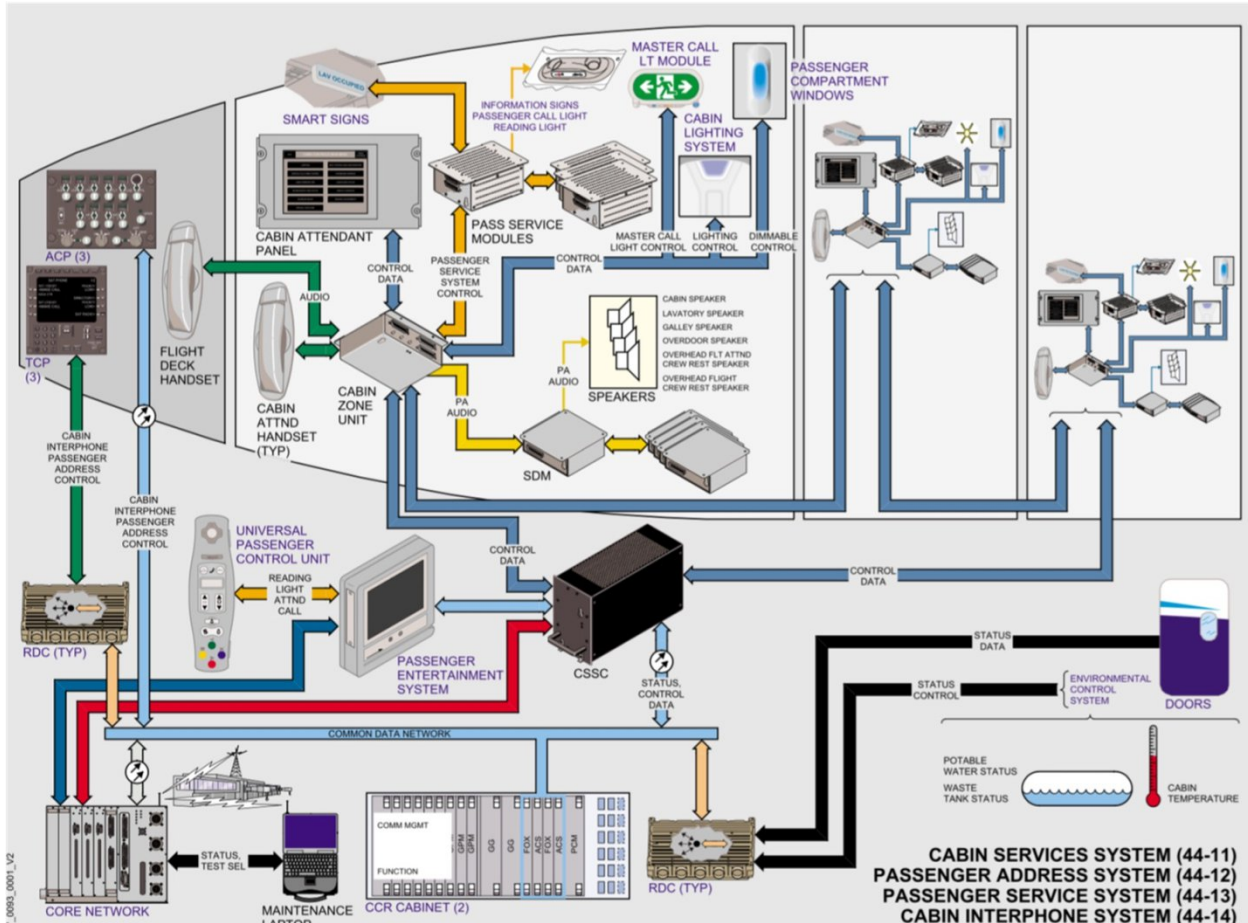

- A: Cabin Services System Controller.
- o B: Cabin Attendant Panel.
- o C: Passenger Control Unit.

132: (Q340) In a hydraulic landing gear system, of which component does a sequence valve ensure proper timing?

- o A: main gear safety switches (proximity switches).
- o B: main gear down locks.
- C: landing gear doors.

133: (Q761) Switching from avionics to flight operation domain is the OIS (On board Information System) is done by....

- A: OIT side switches.
- o B: OIT Terminal processor unit.
- o C: OIT control device.

134: (Q603) Altitude alert is when....

- o A: an alert of the ground proximity is made.
- o B: a decision of whether to land is made.
- C: an alert of the selected altitude of the aircraft is reached.

135: (Q718) Defects of the printer are notified ...

- o A: by a fault report to the CDU (Control Display Unit).
- B: by way of lamps on the front of the panel itself.
- o C: by a fault report to the CMC (Central Maintenance Computer).

136: (Q85) Ionization in the atmosphere is produced chiefly by which of the following types of radiation?

- o A: cosmic radiation.
- B: ultraviolet radiation.
- o C: Alpha radiation.

137: (Q432) The fixed trim tab....

- o A: is manually controlled from the cockpit.
- o B: is riveted to the leading edge.
- C: is adjusted by bending.

138: (Q529) How is communication from the In Flight Entertainment System to a ground station achieved?

- A: Aircraft Communications Addressing and Reporting System (ACARS).
- o B: Automatic Terminal Information System (ATIS).
- o C: Selective Calling System (SELCAL).

139: (Q478) The TCAS 2 (Traffic Collision Avoidance System) provides: 1. traffic information (TA: Traffic Advisory) 2. horizontal resolution (RA: Resolution Advisory) 3. vertical resolution (RA: Resolution Advisory) 4. ground proximity warning The combination regrouping all the correct statements is:

- A: 1 and 3
- o B: 1 and 2
- o C: 1, 2, 3 and 4.

140: (Q486) The antenna of an airborne weather radar is stabilised....

- A: in attitude in relation to the horizontal plane.
- o B: in attitude in relation to the vertical plane.
- o C: in pitch only, when 0o tilt is selected.

141: (Q77) A sound wave that moves back and forth in the direction of propagation is an example of which of the following types of wave motion?

- o A: Longitudinal.
- o B: Concentric.
- C: Transverse.

142: (Q757) The seating and zones are controlled from the cabin configuration software inside the...
(See figure)

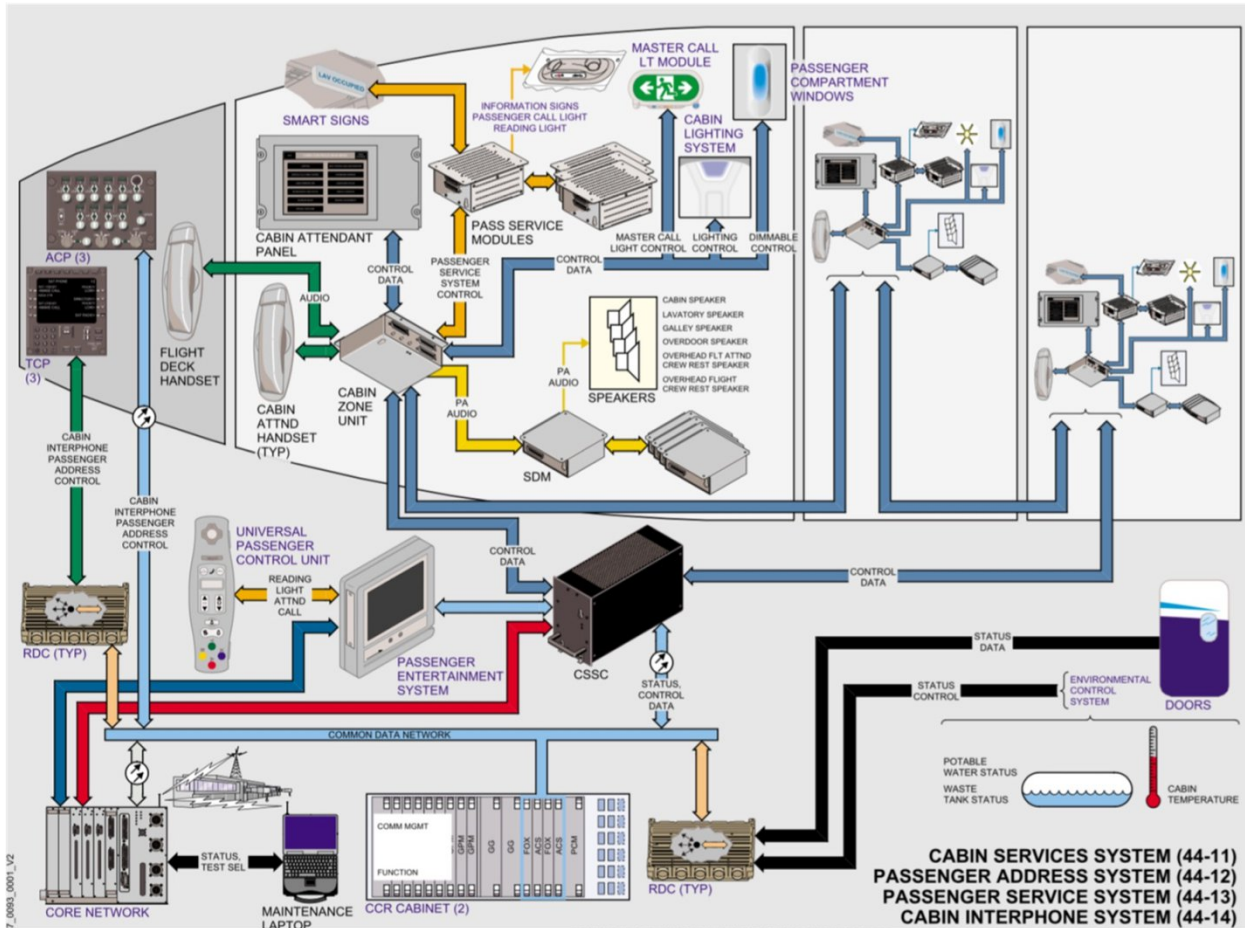

- o A: Passenger Control Unit.
- o B: Cabin Attendant Panel.
- C: Cabin Services System Controller.

143: (Q508) Which one of the following correctly lists the major ground based components of a Microwave Landing System (MLS)?

- o A: Separate azimuth and elevation transmitters, outer and middle marker beacons.
- o B: Combined azimuth and elevation transmitter, marker beacons.
- C: Separate azimuth and elevation transmitters, DME facility.

144: (Q29) To increase critical Mach number

- o A: elevons are fitted.
- B: the wings are swept.
- o C: tailerons are fitted.

145: (Q746) The In-seat audio and video channels and volume can be selected and adjusted by the passenger using the...

- o A: IFES SC (In-flight Entertainment System System Controller).
- o B: IFES AMCU (Advanced Master Control Unit).

- C: IFES PCU (passenger control unit).

146: (Q667) At a given place, compass deviation will:

- A: Vary with aircraft heading.
- o B: Depend on the value of variation.
- o C: Be constant always.

147: (Q622) The sensors used to measure the exhaust gas temperature on an airplane equipped with turbojets are:

- A: Thermocouples.
- o B: Capacitors whose capacity varies proportionally with temperature.
- o C: Based on metallic conductors whose resistance increases linearly with temperature.

148: (Q286) What is the main reason to install only halon-type portable fire extinguisher in the cockpit?

- o A: Because halon fire-bottles can be made much smaller and lighter and so much easier to handle by the pilot from the seat.
- o B: Halon avoids smoke, keeping the cockpit 'visual'.
- C: Because on fires in electronics you may only use halon.

149: (Q697) Stall warning will be given at speeds....

- o A: at the actual stall speed.
- B: lower than stall speed.
- o C: higher than stall speed.

150: (Q499) An ARINC 429 bus uses

- o A: two bi-directional twin sheathed and earthed wires.
- B: a twisted shielded pair of wires.
- o C: a single tin wire cable for each transmitter.

151: (Q442) If during take off (auto throttle engaged) the auto throttle fails, then....

- A: Throttle hold is annunciated.
- o B: Auto pilot disengages.
- o C: Status light illuminates.

152: (Q625) If one probe of a multi-sensor T.G.T. system failed , the reading would:

- A: be practically unaffected.
- o B: fall to zero.
- o C: increase by 20 - 30 degrees C.

153: (Q400) With airspeed hold engaged, Flight Director engaged, a down command means your speed....

- o A: keeps the same.
- o B: has increased.
- C: has decreased.

154: (Q294) What is the purpose of the check valve fitted to a fuel jettison system?

- o A: automatically stop the fuel jettison operation after a period of time.
- B: prevent the dumping of the outer tanks.

o C: prevent the centre from being defueled.

155: (Q707) Access to the Central Maintenance Computers is through....

- A: the line select keys on the CDU.
- o B: a control box.
- o C: a press-to-test switch on the computer itself.

156: (Q510) In which frequency band does the Microwave Landing System (MLS) operate?

- A: SHF
- o B: UHF
- o C: VHF

157: (Q753) Which unit serves as the direct interface with the air-to-ground narrow band or broadband equipment and provides extensive audio, video and cached web content?

- A: The FS (file server).
- o B: The ADB (Area Distribution Box).
- o C: The AMCU (Advanced Master Control Unit).

158: (Q618) An airspeed indicator has....

- o A: pitot connection only.
- o B: static connection only.
- C: pitot and static connection.

159: (Q355) Oxygen for the flight crew of commercial aircraft comes in which form?

- o A: Liquid oxygen.
- o B: Chemical oxygen generators.
- C: Gaseous oxygen.

160: (Q390) The fundamental components of an autopilot control loop are:

- A: rate gyro, servomotor, error signal generator.
- o B: rate gyro, servo motor, torque limiter.
- o C: torque limiter, error signal generator, servomotor.

161: (Q182) What is the function of the flyweight governor (installed in the RAT)?

- o A: It controls the output voltage of the hydraulic motor generator (HMG).
- B: It controls the speed of the ram air turbine.
- o C: It controls the speed of the constant speed motor generator (CSM/G).

162: (Q629) The quantity of fuel in the tanks is measured by capacitor type contents gauges. The working principle of these sensors is to measure the:

- o A: height of the fuel.
- B: charge of condensers.
- o C: di-electric resistivity of the fuel.

163: (Q203) Lights fitted with a dual filament are used as:

- o A: Landing light and runway turn-off light.
- B: Landing light and taxi light.
- o C: Runway turn-off light and engine scan light.

164: (Q405) An automatic flight control system is fitted with control wheel steering (CWS)

- o A: the autopilot must be disengaged before the pilot can input manoeuvring commands.
- B: manoeuvring commands may be input by applying normal force to the control yoke without first disengaging the autopilot.
- o C: the CWS is only there for steering on the ground.

165: (Q758) Which item provides the aircraft crew access to configuration of the IFES, the capability of storing data, and access to passenger database?

- o A: the IFES Advanced Master Control Unit (AMCU).
- o B: the IFES File Server.
- C: the IFES Crew Panel.

166: (Q25) Aerodynamic speeds vary all the way from low subsonic to hypersonic. The limits of supersonic speed range are

- o A: 0.3 to 0.8 M
- B: 1.2 to 5 M
- o C: 0.8 to 1.2 M

167: (Q670) The purpose of fitting an expansion unit to a direct reading compass is to....

- A: compensate for expansion/contraction of the liquid.
- o B: compensate for leaks in the system.
- o C: minimize liquid swirl.

168: (Q766) A pre-departure clearance or PDC is given to the pilots via....

- o A: voice (from ATC).
- o B: the datalink system.
- C: an ACARS message.

169: (Q642) The artificial horizon uses:

- A: a gravity controlled gyro.
- o B: a rate or restrained gyro.
- o C: a horizontally controlled gyro.

170: (Q271) What class of fire can be extinguished with water?

- A: Class A
- o B: All fire classes.
- o C: Class D

171: (Q452) Which is the correct sequence for an autoland?

- o A: Glideslope capture, altitude hold and flare.
- o B: Localiser capture, glideslope capture, flare and attitude hold.
- C: Localiser capture, glideslope capture, attitude hold and flare.

172: (Q282) How are fire bottles without a gauge checked?

- o A: By doing a tap test on the fire bottle.
- o B: No check has to be done as long as the bottle is not used.
- C: By removing from the aircraft and placing on a weighing scale.

- 173: (Q628) The capacitor gauge principle is based on:
- o A: variation of the EMF in a Wheatstone bridge.
 - B: variation of capacitance of a capacitor with the nature of the dielectric.
 - o C: variation of capacitance by volume measure at the probe.
- 174: (Q290) When will a fuel boost pump bypass valve open?
- o A: when both the engine driven and booster pump fail.
 - o B: when the engine driven pump fails.
 - C: when the booster pump fails.
- 175: (Q51) What is a damage tolerant design?
- o A: is applied only to secondary structure.
 - o B: allows for damage to structure but loses its structural strength.
 - C: allows for certain damage to the structure to go un-repaired between scheduled maintenance.
- 176: (Q771) Documentation for the IFE (In-Flight Entertainment) System is part of the...
- o A: Flight Operations Domain.
 - B: Communication & Cabin Domain
 - o C: Avionics Domain
- 177: (Q562) The velocity of sound at the sea level in a standard atmosphere is:
- A: 661 kts.
 - o B: 332 kts.
 - o C: 644 kts.
- 178: (Q538) Aircraft flight control trim systems must be designed and installed so that the....
- o A: trim system will disengage or become inoperative if the primary flight control system fails.
 - o B: operating control and the trim tab will always move in the same direction.
 - C: pilot can determine the relative position of the trimtab from the cockpit.
- 179: (Q461) During autoland all autopilot channels will disconnect in....
- o A: triplex system.
 - o B: dual-dual system.
 - C: duplex system.
- 180: (Q468) The ATC altitude information is relative to....
- o A: 10.92 mbar level.
 - o B: 29.92 bar level.
 - C: 1013.2 mbar level.
- 181: (Q35) What limits the maximum forward speed of a helicopter?
- o A: the shape of the fuselage.
 - B: retreating blade stall and the forward speed of the advancing blade.
 - o C: engine power.
- 182: (Q301) What is the purpose of longitudinal balance fuel systems?
- o A: Carry more fuel.

- B: Keep the center of gravity as close as possible to the ideal position.
 - o C: Trim the aircraft so that there is no need for trimmable horizontal stabilizers.
- 183: (Q674) A FDR fitted to an aircraft of over 5700kgs after April 98 must record for:
- o A: 60 minutes.
 - o B: 30 minutes.
 - C: 25 hours.
- 184: (Q269) On a 'Pull-and-turn' fire switch, when is the fire bottle discharged?
- A: By pulling the handle up and turning the handle to left or right.
 - o B: By pulling the handle up, turning it to one side and pressing the discharge button.
 - o C: By pulling the handle up.
- 185: (Q413) A Stability Augmentation System (SAS) is a rate damping system that will:
- o A: Gives good control and handling characteristics.
 - o B: Stop unwanted rate of motion from developing.
 - C: All of the answers.
- 186: (Q67) What are used on today's aircraft to protect the avionics from lightning strikes?
- o A: Circuit breakers with high sensitivity.
 - B: Bonding wires.
 - o C: Surge protection devices.
- 187: (Q353) What is the result when the steel target is in close proximity to the proximity sensor?
- o A: A failed switch.
 - o B: An open switch.
 - C: A closed switch.
- 188: (Q708) When a..... is displayed, the aircraft is considered unserviceable (only specific failures are permitted to exist as stated in the MEL).
- o A: Maintenance Message.
 - o B: Fault Code.
 - C: Status Message.
- 189: (Q720) A permanent monitoring of the vertical acceleration (G-force) of an aircraft during landing is a part of....
- o A: the 'Low Cycle Fatigue Counter'.
 - B: the 'Damage Tolerance Monitoring'.
 - o C: the 'HUMS' (Health and Usage Monitoring System).
- 190: (Q590) Compressibility error of the ASI is normally corrected by:
- A: The use of the navigation computer by the pilot.
 - o B: The calibration of the instrument.
 - o C: Error is insignificant and can be ignored.
- 191: (Q319) What is the purpose of a mechanical sequence valve?
- A: ensure the correct sequence of landing gears and doors.
 - o B: ensure the correct function of safety switches.

- o C: ensure the correct operation of brake anti-skid units.
- 192: (Q596) The case of an airspeed indicator is fed with:
- A: Static pressure only.
 - o B: Dynamic pressure only.
 - o C: Pitot pressure only.
- 193: (Q189) What is the primary function of a current transformer in an aircraft?
- o A: Step-up the current in a circuit.
 - B: Measure current in an electrical circuit.
 - o C: Measure voltage in an electrical circuit.
- 194: (Q351) What is the advantage that stress sensors have over other air/ground sensing systems?
- A: Can measure aircraft weight.
 - o B: Easier to replace.
 - o C: More reliable.
- 195: (Q470) What is the correct response to a TCAS RA?
- A: Pilots follow the climb or descent commands smoothly and immediately.
 - o B: Pilots have to follow ATC instructions as these override TCAS RA's.
 - o C: Pilots turn 90° and they follow the climb or descent commands smoothly and immediately.
- 196: (Q403) When being engaged, and without selecting a particular mode, an automatic pilot enables....
- o A: a constant speed on track, wings horizontal.
 - B: aeroplane stabilisation with attitude hold.
 - o C: all aeroplane piloting and guidance functions except maintaining radio-navigation course lines.
- 197: (Q641) Using a compensated vacuum-driven attitude indicator during a turn....
- o A: there will be indication errors in pitch only.
 - B: the indications will be corrected for a selected speed and rate of turn.
 - o C: there will be indication errors in pitch and roll.
- 198: (Q221) Where is the water separator located?
- o A: Downstream of anti ice valve.
 - o B: Downstream of the turbine.
 - C: Downstream of the compressor.
- 199: (Q110) The Selcal (Selective Calling) can be used by....
- o A: HF system only.
 - B: VHF and HF systems.
 - o C: VHF system only.
- 200: (Q82) An increase in the frequency of a radio wave will have what effect, if any, on the velocity of the radio wave?
- A: None.
 - o B: Increase.
 - o C: Decrease.

201: (Q73) What is the major advantage of the telegraph over earlier methods of communication?

- A: Range and speed.
- o B: Larger messages.
- o C: Security.

202: (Q457) Until touchdown, auto pilot, with auto-land system....

- o A: disconnects after a short time.
- B: remains engaged ready for G/A.
- o C: drives the throttles forward.

203: (Q66) What is used to protect the nose radome from lightning strikes?

- o A: Bonding wire.
- B: Lightning diverter strips.
- o C: The radome is composite material and does not require a special lightning protection.

204: (Q749) The inflight entertainment equipment is connected to ...

- o A: its own network system, completely isolated from the Core network system.
- o B: the IDN (Isolated Data Network) of the Core network system.
- C: the ODN (Open Data Network) of the Core network system.

205: (Q497) What is the Speed of an ARINC 429 system?

- A: 100 kbits/s
- o B: 2 - 6 Gbits/s.
- o C: 2.3 - 23 Mbits/s

206: (Q434) The auto throttle system is: 1. able to catch and maintain the N1 RPM. 2. able to catch and maintain the N2 RPM. 3. able to catch and maintain an airplane indicated airspeed IAS. 4. always engaged automatically at the same time as the autopilot. The combination regrouping all the correct statements is:

- A: 1 and 3.
- o B: 2 and 3.
- o C: 1 and 4.

207: (Q373) How are the gyroscopes in a pneumatic gyro instrument system on an aircraft at high altitude driven?

- o A: By ram air.
- o B: By bleed air pressure.
- C: By air pump suction.

208: (Q560) Which of the following instruments are navigation instruments? 1. air speed indicator. 2. altimeter. 3. gyro horizon. 4. global navigation satellite system. 5. Inertial reference system.

- o A: 3, 4 and 5.
- o B: 1, 2 and 3.
- C: 4 and 5.

209: (Q335) What does a green/grey spot marking on aircraft tyre casing represent?

- o A: The light part of the tyre.

- o B: Military reference.
- C: Leak holes.

210: (Q723) Maintenance Information at an out-station can be read from the....

- o A: FMS (Flight Management system).
- B: CDU (Control Display Unit).
- o C: Electronic library system.

211: (Q417) The purpose of Automatic Trim function in autopilot is to....

- A: control elevator trim tab in order to relieve elevator load.
- o B: trim throttles to obtain smooth engine power variation.
- o C: tell the pilot when elevator trimming is required.

212: (Q677) The displays marked A, B, C and D are respectively: (See the figure)

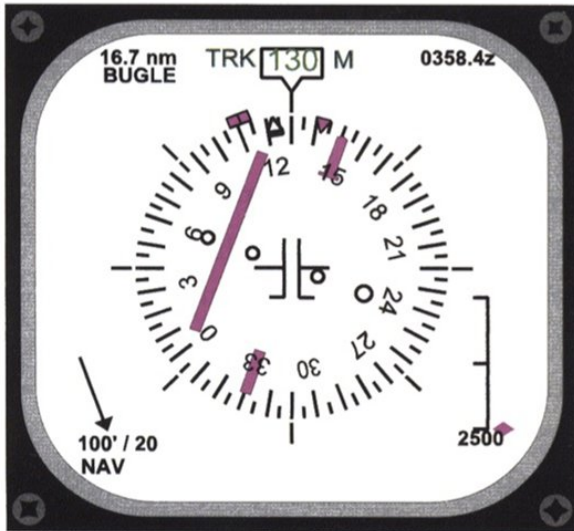

A



B



C



D

- A: A. NAV - B. PLAN - C. VOR - D. ILS
- o B: A. VOR - B. ILS - C. NAV - D. Plan
- o C: A. MAP - B. VOR - C. ILS - D. Plan

213: (Q446) In order to know in which mode the autothrottles are engaged, the crew will check the:

- o A: throttles position.
- o B: ND (Navigation Display).
- C: PFD (Primary Flight Display).

214: (Q467) Secondary Surveillance Radar is a form of .(1)..radar with .(2)..type emissions operating in the .(3)..band.

- A: (1) secondary - (2) pulse - (3) UHF
- o B: (1) primary - (2) pulse - (3) SHF

o C: (1) secondary - (2) FM - (3) SHF

215: (Q382) A single axis autopilot system provides....

- o A: control about the pitch axis.
- B: control about the roll axis.
- o C: stabilisation about the normal axis.

216: (Q384) A three-axis auto pilot is....

- A: an auto stabilisation system.
- o B: a system which will maintain a preselected airspeed.
- o C: a system which will maintain a preselected altitude.

217: (Q739) This is a.... (See the figure)



- o A: RJ61 connector.
- o B: RJ12 connector.
- C: RJ45 connector.

218: (Q722) Which system can also be used to monitor the aircraft's structure and thus identify any faults before they cause catastrophic failure.

- o A: the Electronic library system.
- B: the Flight Data Recorder.
- o C: the CDU (Control Display Unit).

219: (Q210) Which of the following statements is incorrect? A turbo compressor....

- o A: is used as a supplemental use source of bleed air.
- B: is used on turbo-prop and piston engine.
- o C: can be switched on and off by the crew.

220: (Q608) In An Air Data Computer (ADC), aeroplane altitude is calculated from:

- o A: Measurement of elapsed time for a radio signal transmitted to the ground surface and back.
- o B: The difference between absolute and dynamic pressure at the fuselage.
- C: Measurement of absolute barometric pressure from a static source on the fuselage.

221: (Q620) Direct reading aircraft thermometer usually consists of a bimetallic element protruding into the airstream. Movement of the pointer over the temperature scale will depend on:

- o A: increase in pressure as airspeed increases.
- B: different coefficients of expansion of the two metals.
- o C: difference in electrical resistance of the two metals.

222: (Q415) A duplex SAS (Stability Augmentation System) architecture ensures that a lane failure results in....

- o A: a setting which limits the movement of the two lane actuators.
- B: only a passive failure, that is, the output of the two lane actuators remains at the position it was in at the time of failure.
- o C: a passive failure with the system reverting to manual operation.

223: (Q323) What causes ice formation on wings?

- A: supercooled water changing state on contact with the wing.
- o B: suspended ice crystals melting on contact with the wing and instantly re-freezing.
- o C: ice crystals forming layers on contact with the wing.

224: (Q199) What is 'no breaks power transfer'?

- o A: Power supply remains with the same source even though power transfer to another source has been selected.
- o B: Power supply is transferred from one source to another while bypassing the circuit breakers.
- C: Power supply is transferred from one source to another without interrupting the supply.

225: (Q406) Inputs to the rudder channels initially originate from

- o A: servomotors.
- o B: AH (altitude hold) gyro and turn and slip gyro.
- C: compass gyro and turn and slip gyro.

226: (Q225) When the refrigerant loses heat in a vapour cycle system....

- A: the vapour converts to a liquid.
- o B: the liquid evaporates to the environment.
- o C: the liquid converts to a vapour.

227: (Q331) What must be done when testing windshield wipers?

- o A: operate them on a dry windshield.
- o B: lift the wipers away from the windshield.

- C: use a continuous flow of water on the windshield.

228: (Q534) Anti-servo tabs....

- o A: move in the opposite direction to the control surface.
- o B: are directly connected to the control column.
- C: move in the same direction as the control surface.

229: (Q273) What ensures that the agent (Halon 1211) is dispersed in the shortest time possible in a high rate discharge bottle?

- A: Nitrogen.
- o B: Oxygen.
- o C: Halon 1301 or Nitrogen.

230: (Q568) Dynamic Pressure is:

- o A: Static pressure minus pitot pressure.
- B: Total pressure minus static pressure.
- o C: Pitot pressure plus static pressure.

231: (Q652) The indication of the directional gyro as an on-board instrument are valid only for a short period of time. The causes of this inaccuracy are: 1. The earth's rotation. 2. The longitudinal acceleration. 3. The aircraft's motion over the surface of the earth. 4. The mechanical defects of the gyro. 5. The gyro's weight. 6. The gimbal mount of the gyro rings. The combination of correct statements is:

- o A: 2, 5, 6.
- B: 1, 3, 4, 6.
- o C: 1, 3, 4.

232: (Q741) This is a(n).... (See the figure)

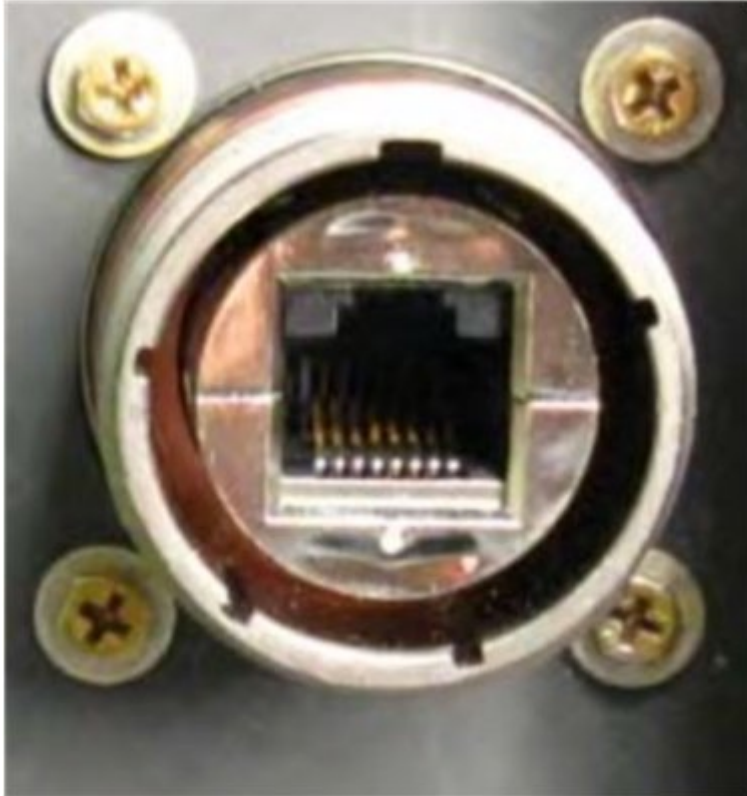

o A: RJ45 port.

- o B: Quadrax port.
- C: Ethernet port.

233: (Q545) The type of flap that extends rearward from the trailing edge as it is lowered is....

- o A: a Zap flap.
- B: a Fowler flap.
- o C: a Kreuger flap.

234: (Q490) For most radio altimeters, when a system error occurs during approach the

- o A: DH lamp flashes red.
- o B: DH lamp flashes red and the audio signal sounds.
- C: Height indication is removed.

235: (Q315) What allows a hand pump, which is normally a single cylinder, to operate as a double acting pump?

- o A: piston ram displacement.
- o B: relief valve.
- C: two non-return valves fitted.

236: (Q724) Waste water drain mast....

- A: are heated to a lower temperature with the aircraft on ground.
- o B: are not heated.
- o C: are heated to a high temperature in the air and on ground.

237: (Q132) In an ADF system, night effect is most pronounced:

- o A: when the aircraft is at high altitude.
- B: at dusk and dawn.
- o C: during long winter nights.

238: (Q306) One reason for fitting an accumulator in a hydraulic system is to....

- A: absorb pressure surges.
- o B: relieve excess pressure.
- o C: minimize the possibility of pump cavitation.

239: (Q672) The flight data recorder must automatically stop data recording when the....

- A: the airplane is on the ground and the engines are turned off.
- o B: main gear shock strut compresses when touching the runway.
- o C: airplane clears the runway.

240: (Q186) In a parallel bus configuration the generators will:

- A: Share the load equally among them.
- o B: Each supply their own AC bus.
- o C: Divide the load, with the strongest generators taking the biggest load.

241: (Q80) Varying which of the following wave characteristics will cause the length of sound waves to vary?

- o A: Amplitude.
- o B: Phase.
- C: Frequency.

242: (Q631) A float fuel gauge system is....

- A: adjusted when tanks are empty.
- o B: adjusted when tanks are full.
- o C: cannot be adjusted.

243: (Q74) Radio-frequency waves cannot be seen for which of the following reasons?

- A: Because radio-frequency waves are below the sensitivity range of the human eye.
- o B: Because radio-frequency waves are above the sensitivity range of the human eye.
- o C: Because radio-frequency energy is low powered.

244: (Q191) Which formula represents the transformer ratio?

- A: $V_2 / V_1 = N_2 / N_1$
- o B: $V_2 \times V_1 = N_2 \times N_1$
- o C: $V_2 / N_2 = V_1 / N_1$

245: (Q209) The external emergency lights are used for:

- o A: Identifying the entry doors to help rescue workers locate them.
- o B: Illuminating the area around the aircraft to help rescue workers.
- C: Illuminating the escape slides.

246: (Q86) The density of ionized layers is normally greatest during which of the following periods?

- o A: Between afternoon and sunset.
- B: Between early morning and late afternoon.

- o C: At night.
- 247: (Q475) A 'TCAS II' (Traffic Collision Avoidance System) provides:
- o A: the intruder relative position and possibly an indication of a collision avoidance manoeuvre within the horizontal plane only.
 - B: the intruder relative position and possibly an indication of a collision avoidance manoeuvre within the vertical plane only.
 - o C: a simple intruding airplane proximity warning..
- 248: (Q409) When the aircraft nose yaws to the left, the yaw damper will apply corrective rudder to
- o A: the left.
 - o B: the left with some aileron assistance.
 - C: the right.
- 249: (Q176) In which type of unit can a permanent magnet generator (PMG) be found?
- o A: DC alternator.
 - o B: DC generator.
 - C: Brushless AC alternator.
- 250: (Q105) The mode of operation of the VHF comms transceiver is
- A: single channel simplex.
 - o B: double channel duplex.
 - o C: single channel duplex.
- 251: (Q376) A full operational autopilot system will ensure that
- o A: the automatic pilot will automatically cause the aircraft to overshoot if any failure is detected.
 - o B: the automatic pilot will automatically disengage whenever any failure is detected.
 - C: the aircraft will continue its automatic landing in the event of a single failure.
- 252: (Q190) Which of the following statements about current transformers is true?
- o A: Current transformers always have a square transformer core.
 - o B: The primary winding should never be left open when in operation.
 - C: The secondary winding should never be left open when in operation.
- 253: (Q610) While carrying out a leak check of the altimeter, if the static is leaking, the VSI would:
- o A: not be affected.
 - B: indicate decent.
 - o C: indicate climb.
- 254: (Q131) A conventional VOR....
- o A: has an AM reference signal and a FM variable signal.
 - B: has an FM reference signal and an AM variable signal.
 - o C: has an AM reference signal and a 150 Hz variable signal.
- 255: (Q377) To carry out an autopilot check first
- o A: switch on NAV receivers.
 - o B: switch off all power.
 - C: ensure all control surfaces are unobstructed.

- 256: (Q339) On all aircraft equipped with retractable landing gear, some means must be provided to ..
- o A: prevent extension of the landing gear at airspeeds greater than that determined structurally safe.
 - o B: retract and extend the landing gear if the normal operating mechanism fails.
 - C: extend the landing gear if the normal operating mechanism fails.

- 257: (Q570) Pressure errors which can be calculated and presented graphically in the aircraft manual include:
- o A: Configuration, maneuver and turbulence errors.
 - B: Position and configuration errors.
 - o C: Position and maneuver errors.

- 258: (Q760) Which part of the avionics domain of the network server system gives a single way of communication, preventing malicious data coming going to the avionics domain?
- o A: ethernet gateway module.
 - o B: secure communication interface.
 - C: open world diode.

- 259: (Q728) The standardized Real-Time Operating system used in IMA uses the.....
- o A: RTOS specification.
 - B: ARINC 653 specification.
 - o C: ARINC 429 specification.

260: (Q681) The symbols A, C and E are best described respectively as: (See the figure)

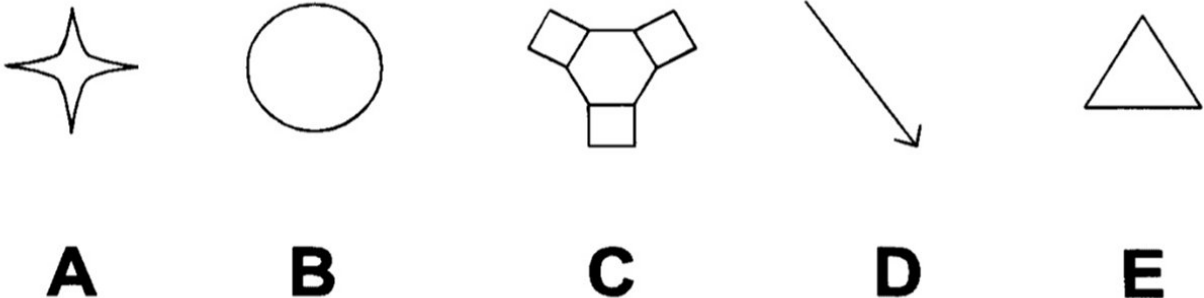

- A: (A) active waypoint aircraft currently navigating to - (C) navigation aid - (E) off route waypoint.
- o B: (A) next waypoint - (C) navigation aid - (E) airport.
- o C: (A) off route waypoint - (C) navigation aid - (E) a navigation point making up selected route.

- 261: (Q346) In an anti-skid system ...
- o A: brakes release on rising torque.
 - o B: brakes release on falling torque.
 - C: brakes are modulated to give most efficient braking.

- 262: (Q260) What is the sniffer used for?
- o A: To detect fire in the avionics compartment.
 - B: To detect smoke in avionics compartment.
 - o C: To detect smoke on the flight deck.

263: (Q474) The principle of the TCAS (Traffic Collision Avoidance Systems) is based on the use of :

- o A: air traffic control radar systems.
- o B: airborne weather radar system.
- C: transponders fitted in the aircraft.

264: (Q56) Safe-life is

- o A: the maximum number of flying hours that should elapse before a major structural failure occurs.
- o B: the sharing of loads between adjacent members.
- C: the minimum number of flying hours that should elapse before a major structural failure occurs.

265: (Q588) The purpose of the IVSI is to:

- o A: compensate for the change of pressure when initiating a climb or descent.
- B: give an instantaneous indication of the aircraft's vertical speed when a climb or descent has been initiated.
- o C: instantaneously indicate to the pilot when an aircraft pitches, especially in steep turns.

266: (Q494) What does the term AIR-GROUND COMMUNICATION mean?

- o A: One-way communication from stations or locations on the surface of the earth.
- o B: Any communication from aircraft to ground station requiring handling by the Aeronautical Fixed Telecommunication Network (AFTN).
- C: Two-way communication between aircraft and stations or locations on the surface of the earth.

267: (Q679) The centre of the weather return is : (See the figure)



- A: 332° relative, 13 nm.
- o B: 106° relative, 18 nm.
- o C: 30 nm left of track, 15 nm ahead.

268: (Q34) How does a rotor generate lift?

- A: low pressure above the blade.
- o B: high pressure above the blade.
- o C: down-wash below the blade.

269: (Q613) Static ports are usually fitted to both sides of the aircraft fuselage. This will:

- o A: reduce the position error.
- B: balance out errors caused by side slipping or yawing.
- o C: enable a greater number of instruments to be fitted.

270: (Q525) The PA amplifier sets the priority for the audio inputs. Which has the highest priority?

- o A: Announcement from an attendant.
- B: Announcement from the flight compartment.
- o C: Boarding Music.

271: (Q246) What are the basic flight deck indications for pressurization?

- o A: Aircraft altitude, rate of climb and atmospheric pressure.
- o B: Cabin altitude, ambient temperature and pressure differential.
- C: Cabin altitude, cabin rate of climb and pressure differential.

272: (Q114) When activated, the battery of an ELT must be capable of furnishing power for signal transmission for at least ...

- A: 48 hours.
- o B: 28 days.
- o C: 24 hours.

273: (Q48) What happens to the RPM of the rotor, when lifting the collective lever during an autorotative descent?

- o A: remain the same.
- B: reduce.
- o C: increase.

274: (Q313) What is the normal operating pressure of a hydraulic system?

- o A: 300 PSI.
- B: 3000 PSI.
- o C: 1800 PSI.

275: (Q242) The outflow valve of a pressurized cabin system opens when the cabin pressure is....

- o A: too low or too high.
- o B: too low.
- C: too high.

276: (Q171) What type of generator / alternator is used in a variable speed constant frequency system?

- A: DC alternator.
- o B: Brushless alternator.
- o C: DC generator.

277: (Q435) At the missed approach point the TOGA switch on the throttles is depressed. Which of the following statements are correct: 1. Pilot selects maximum power. 2. Auto-throttle selects GA power. 3. Aircraft automatically cleans up. 4. Auto-pilot flies the GA. 5. Pilot flies the GA manoeuvre. The combination regrouping all the correct statements is:

- o A: 1 and 4
- B: 2 and 4
- o C: 1 and 5

278: (Q459) An aircraft will capture the auto land system at

- o A: 3500 ft.
- B: 1500 ft.
- o C: 2500 ft.

279: (Q173) What is the output speed of a constant speed drive?

- A: 6000rpm
- o B: 12000rpm
- o C: Variable speed depending on engine speed.

280: (Q154) What is the pseudo-random code used by all civilian GPS users?

- A: the C/A code.
- o B: the P code.
- o C: the Y code.

281: (Q321) Under which condition does an air pressure operated ice detector work?

- o A: It has to be completely covered in ice before causing an alarm to sound on the flight deck.
- B: A build up of ice on the leading edge causes a warning light to illuminate on the flight deck.
- o C: A build up of ice causes a torque switch to illuminate a flight deck annunciator.

282: (Q484) Airborne Weather Radar is an example of..... radar operating on a frequency of..... in the.....band.

- o A: secondary - 9375 MHz - SHF
- B: primary - 9375 MHz - SHF
- o C: secondary - 9.375 MHz - UHF

283: (Q480) Weather Radar returns show areas of precipitation in the following colors:

- o A: Green, Magenta, Blue and Red.
- o B: Green, Orange, Yellow and Red.
- C: Green, Yellow, Red and Magenta.

284: (Q436) The autothrottle maintains a specific value of thrust in terms of:

- o A: N2, Mach and airspeed.
- B: EPR, N1, Mach and airspeed.
- o C: N1, Mach and airspeed.

285: (Q577) In high speed flight at high altitude, the static source will suffer:

- o A: barometric error.
- o B: temperature error.
- C: position error.

286: (Q46) Where is the helicopter throttle hand grip located?

- o A: throttle box.
- o B: cyclic stick.
- C: collective lever.

287: (Q469) The special 'Ident' feature (SPI-code)....

- o A: is to confirm TCAS identity.
- o B: is to confirm SELCAL identity.
- C: allows ATC to confirm aircraft identity.

288: (Q426) Mode 'Localizer ARM' active on Flight Director means:

- o A: Localizer is armed and coupling will occur when flag warning disappears.
- B: System is armed for localizer approach and coupling will occur upon capturing center line.
- o C: Coupling has occurred and system provides control data to capture the centerline.

289: (Q463) A landing will be considered to be performed in the AUTOMATIC mode when: 1. the autopilot maintains the airplane on the ILS beam until the decision height is reached then is disengaged automatically. 2. the auto throttle maintains a constant speed until the decision height is reached then is disengaged automatically. 3. the autopilot maintains the airplane on the ILS beam until the flare. 4. the auto throttle decreases the thrust when the height is approximately 30 ft. 5. the flare and the ground roll are performed automatically. The combination regrouping all the correct statements is:

- o A: 1 and 4.
- o B: 2, 3 and 5.
- C: 3, 4 and 5.

290: (Q310) How do you prevent hydraulic fluid foaming?

- o A: pass over a tray.
- B: by pressurising.
- o C: vent reservoir to atmosphere.

291: (Q518) Due to 'Doppler' effect an apparent decrease in the transmitted frequency, which is proportional to the transmitter's velocity, will occur when the transmitter....

- o A: and receiver move towards each other.
- o B: moves toward the receiver.
- C: moves away from the receiver.

292: (Q647) On an instrument check whilst taxiing, when carrying out a turn, the ball on the turn and bank indicator should indicate:

- A: a skid out of the turn.
- o B: a slip into the turn.
- o C: no slip or skid.

293: (Q438) An automatic throttle, engaged in the EPR mode, will control

- o A: the engine throttles to maintain a constant acceleration rate.
- o B: the aircraft altitude to maintain constant engine input pressure.
- C: the engine throttles to maintain a constant engine power setting.

294: (Q357) How does an 'on board oxygen generation system' (OBOGS) produce oxygen?

- o A: By using sodium chloride.
- o B: By electrolysis of water.
- C: By using molecular filters.

295: (Q96) Uniform capacitance throughout the length of the line is an advantage of which of the following transmission lines?

- A: Shielded pair.
- o B: Twisted pair.
- o C: Coaxial line.

296: (Q58) Pressure Error (PE) will cause an altimeter to:

- o A: consistently under-read in a climb or descent.
- o B: only over-read in a climb.
- C: either over-read or under-read in level flight.

297: (Q169) The output of a single coil generator is

- o A: a flat line.
- B: a sine-wave.
- o C: a saw foot.

298: (Q725) How are drinking water pipes prevented from freezing?

- o A: Installation of neoprene foam insulation.
- o B: Placing the pipes adjacent to hot water piping.
- C: Wrapping the pipes with heated tapes or blankets.

299: (Q388) Coordinated autopilot turns are achieved by

- A: yaw rate gyro signals.
- o B: aileron to elevator crossfeed.
- o C: aileron to rudder crossfeed.

300: (Q536) What must you do to yaw the aircraft to the right?

- o A: The left rudder pedal is pushed forward and the rudder moves to the left.
- o B: The right rudder pedal is pushed forward and the rudder moves to the left.
- C: The right rudder pedal is pushed forward and the rudder moves to the right.

301: (Q270) Some aircraft are fitted with 2 types of fire bottles: dump and metered bottles, used in the cargo compartment. Why is this?

- o A: To extinguishing different types of fires.
- B: To ensure the concentration of extinguishing agent remains high enough for 180 minutes.
- o C: To ensure there is enough extinguishing agent for the whole aircraft.

302: (Q98) An antenna that can be mounted to radiate rf energy either vertically or horizontally is classified as which of the following types?

- o A: Marconi.
- B: Hertz.
- o C: Quarter-wave.

303: (Q542) Where are the gust suppression pressure transducers located? On both sides of...

- o A: the aircraft (nose and tail) to measure the pressure differences between the nose and tail (slip).
- B: the vertical stabilizer to measure the pressure differences between the sides of the tail.
- o C: the horizontal stabilizer to measure the pressure differences between the bottom and top side of the stabilizer.

304: (Q404) Automatic flight systems may be capable of controlling the aircraft flight in:

- o A: azimuth and velocity only.
- o B: azimuth and elevation only.
- C: azimuth, elevation and velocity.

305: (Q503) ARINC 429 SDI word format is at bits

- o A: 1 - 8
- o B: 31 - 32
- C: 9 - 10

306: (Q140) The IRS position can be initialized....

- A: on the ground only.
- o B: on the ground and in flight with VOR/DME.
- o C: at designated positions en-route and on the ground.

307: (Q344) Which of the following are characteristics of a carbon brake?

- o A: have less weight than normal brake units but fade away at high temperatures.
- o B: weigh the same as normal brake units and fade away at high temperatures.
- C: have less weight than normal brake units and have increased efficiency at high temperatures.

308: (Q559) The advantages of fly-by-wire control are: 1. reduction of the electric and hydraulic power required to operate the control surfaces 2. lesser sensitivity to lightning strike 3. direct and indirect weight saving through simplification of systems 4. immunity to different interfering signals 5. improvement of piloting quality throughout the flight envelope The combination regrouping all the correct statements is:

- A: 3 and 5
- o B: 1, 4 and 5
- o C: 2 and 3

309: (Q575) If the static vent becomes blocked on an unpressurized aircraft, what could the pilot do?

- o A: Select standby pitot source.
- o B: Open the window.
- C: Break the VSI glass.

310: (Q700) An engine vibration indicator receives a signal from different sensors (accelerometers). It indicates the:

- o A: Acceleration measured by the sensors, expressed in g.
- B: Vibration amplitude at a given frequency.
- o C: Vibration frequency expressed in Hz.

311: (Q87) Compared to the other ionospheric layers at higher altitudes, the ionization density of the D layer is

- A: relatively low.
- o B: relatively high.
- o C: about the same.

312: (Q352) On aircraft with bogie beams (trucks), what is used to detect air/ground?

- o A: Squat switches.
- o B: Weight-on-wheel switches.
- C: Truck tilt switches.

313: (Q214) The RAM air supply is used....

- o A: only on unpressurized aircraft.

- B: as an emergency air source on pressurized aircraft to ventilate the cockpit and the cabin.
- o C: as an alternate source to power the air-conditioning packs.

314: (Q655) A slaved directional gyro derives its directional signal from:

- o A: The air data computer.
- o B: A direct reading magnetic compass.
- C: The flux valve.

315: (Q63) What is the measurement of the fuselage location along the Z-coordinate?

- A: water line.
- o B: fuselage station.
- o C: butt line.

316: (Q92) At frequencies above 100 MHz, the greatest attenuation of rf energy from raindrops is caused by which of the following factors?

- o A: absorption.
- o B: ducting.
- C: scattering.

317: (Q267) A systron-Donner fire detection system uses.....

- o A: nitrogen gas.
- o B: air.
- C: helium gas.

318: (Q81) What will be the effect on the wavelength of radio wave if the frequency increases? The wavelength....

- o A: will increase.
- B: will decrease.
- o C: is not influenced.

319: (Q775) Which of the following instruments are flight instruments? 1. Air speed indicator. 2. Altimeter. 3. Gyro horizon. 4. Global navigation satellite system. 5. Inertial reference system.

- o A: 3, 4 and 5.
- o B: 1, 3 and 5.
- C: 1, 2 and 3.

320: (Q765) Documentation (FCOM, MEL, AFM, CDL) is part of the ...

- o A: Communication & Cabin Domain.
- o B: Avionics Domain.
- C: Flight Operations Domain.

321: (Q70) With reference to antennas, parasitic elements are:

- o A: dipole or folded dipole radiating elements.
- o B: unfed elements which make the antenna radiation pattern omnidirectional.
- C: unfed elements which make the radiation pattern directional.

322: (Q601) An 'altitude alerting system' must at least warn the crew: 1. when approaching the pre-selected altitude; 2. when the airplane is approaching the ground too fast; 3. in case of a given

deviation above or below the pre-selected altitude (at least by an aural warning); 4. in case of excessive vertical speed; 5. when approaching the ground with the gear retracted. The combination regrouping all the correct statements is:

- o A: 1, 3, 4.
- o B: 2, 4, 5.
- C: 1, 3.

323: (Q118) The Cockpit Voice Recorder of an aircraft of 5700 kg or less will always store the :

- o A: last 120 minutes.
- B: last 30 minutes.
- o C: last 60 minutes.

324: (Q50) Which of the following is an example of a failsafe structure?

- o A: Nose radome.
- o B: Single stringer.
- C: Multiple Spars.

325: (Q379) Flight director command bars indicate

- o A: Direction in which aircraft is flying.
- B: Direction in which aircraft is to be manoeuvred.
- o C: Direction in which the beacon is.

326: (Q646) When turning right onto the runway prior to take-off, the ball on the turn and bank indicator will:

- o A: stay central in the turn.
- o B: move to the right.
- C: move to the left.

327: (Q362) A green disk on the side of the fuselage is missing, what does this indicate?

- o A: The maximum pressure in the oxygen supply lines has been exceeded.
- B: The maximum pressure in the oxygen cylinder has been exceeded.
- o C: The oxygen bottle pressure is below operational limits.

328: (Q232) Temperature control of cabin air is achieved by....

- A: regulating the amount of hot air added to the conditioned air.
- o B: varying the ambient airflow to the heat exchanger.
- o C: controlling the speed of the air cycle machine.

329: (Q477) The TCAS (Traffic Collision Avoidance System) is a proximity alarm system which detects a 'traffic' when the conflicting traffic is equipped with a:

- o A: SELCAL system.
- B: serviceable mode S or SSR transponder.
- o C: DME system.

330: (Q58) What is ATA Zone 100?

- A: lower fuselage.
- o B: upper fuselage.
- o C: vertical fin.

331: (Q393) Which modes are incompatible?

- o A: VOR + ALTITUDE HOLD
- o B: HDG + V/S HOLD
- C: G/S + ALTITUDE HOLD

332: (Q567) Pitot pressure is a combination of:

- A: Static pressure and dynamic pressure.
- o B: Static pressure and position error.
- o C: Dynamic pressure and position error.

333: (Q683) Airspeed is shown:

- o A: only on the pilot in commands EHSI.
- o B: on both EHSIs.
- C: on both EADIs.

334: (Q4) When inner and outer ailerons are mounted, outer ailerons are used:

- A: at low speeds.
- o B: during take-off only.
- o C: at high speeds.

335: (Q240) How is the pressure inside the cabin controlled?

- o A: By regulating the air conditioning pack output pressure.
- B: By using one or more outflow valves.
- o C: By controlling the amount of bleed air to the air conditioning packs.

336: (Q640) The inner gimbal assembly of an attitude indicator is pivoted..(1)..... in the...(2).....

- o A: (1) longitudinally - (2) outer gimbal.
- o B: (1) longitudinally - (2) rolling plane.
- C: (1) to give freedom - (2) pitch plane.

337: (Q774) All the last generation aircraft use flight control systems. The FMS is the most advanced system. It can be defined as a....

- o A: management system optimized in the horizontal plane.
- B: 3-axis Flight Management System.
- o C: 2-axis Flight Management System.

338: (Q55) How are skin panels strengthened?

- o A: cleats.
- o B: struts.
- C: stringers.

339: (Q262) In a pneumatic fire sensor, what triggers the fire warning?

- A: The pressure increase caused by the release of gas from the absorption material acting on a pressure switch.
- o B: The difference pressure between static air pressure and expended air pressure.
- o C: The temperature of the gas inside the steel tubing acting on a temperature switch.

340: (Q516) The best fix for hyperbolic navigation is when the lines of position (LOP) intersect....

- o A: in a diagonal angle.
- o B: at the greatest curve.
- C: at an angle of 90o.

341: (Q464) During a Category II automatic approach, the height information is supplied by the:

- o A: encoding altimeter.
- o B: altimeter.
- C: radio altimeter.

342: (Q606) What are the inputs to the ADC ? 1. OAT. 2. Dynamic pressure. 3. TAT. 4. Static pressure. 5. Vertical speed. 6. Pitot pressure.

- A: 3, 4 and 6.
- o B: 3, 4, 5 and 6.
- o C: 1, 2, 5 and 6.

343: (Q295) In what position is the fuel crossfeed valve, when it is not used?

- o A: its last position.
- o B: the open position.
- C: the closed position.

344: (Q389) The Altitude Select System:

- o A: Engages autopilot Auto Trim at selected altitude.
- B: Is annunciated by light and/or sound when airplane is approaching selected altitude.
- o C: Disengages autopilot Auto Trim at selected altitude.

345: (Q630) In a capacitive fuel gauging system an increase in fuel level would:

- A: increase capacitance.
- o B: increase capacitive reactance.
- o C: decrease capacitance.

346: (Q668) In a direct reading compass, horizontality is achieved by....

- o A: changing the magnet system in a liquid-filled bowl.
- o B: using jeweled bearings.
- C: using pendulous suspension.

347: (Q157) Which of the following combinations of satellite navigation systems provide the most accurate position fixes in air navigation?

- o A: GLONASS and COSPAS-SARSAT.
- o B: NNSS-Transit and GLONASS.
- C: NAVSTAR/GPS and GLONASS.

348: (Q496) ADS-B: 1. broadcasts information about aircraft, such as identification, current position, altitude and velocity. 2. provides air traffic controllers with real-time position information. 3. receives Flight Information data. 4. receives Traffic Information Service data. 5. receives other ADS-B Out broadcasting aircraft.

- A: 1, 2, 3, 4 and 5.
- o B: 1, 3 and 5.

o C: 2, 4 and 5

349: (Q108) The HF (high frequency) range of the radio spectrum is the band extending from

- o A: 300 MHz to 3 GHz
- B: 2 - 30 MHz
- o C: 30 MHz to 300 MHz.

350: (Q565) The pressure probe used to measure the pressure of a low pressure fuel pump is:

- o A: a capacitor.
- B: a Bourdon tube.
- o C: a bellows sensor.

351: (Q509) Which one of the following is an advantage of a Microwave Landing System (MLS) compared with an Instrument Landing System (ILS)?

- A: It is insensitive to geographical site and can be installed at sites where it is not possible to use an ILS.
- o B: There is no restriction on the number of ground installations that can be operated because there is an unlimited number of frequency channels available.
- o C: The installation does not require to have a separate method (marker beacons or DME) to determine range.

352: (Q317) What happens if a component has an internal hydraulic leak?

- A: increase in fluid temperature.
- o B: fluid loss.
- o C: increase in fluid pressure.

353: (Q83) The bending of a radio wave because of a change in its velocity through a medium is known as....

- o A: diffraction.
- o B: reflection.
- C: refraction.

354: (Q614) Direct reading aircraft thermometer usually consists of a bimetallic element protruding into the airstream. Movement of the pointer over the temperature scale will depend on:

- o A: increase in pressure as airspeed increases.
- B: different coefficients of expansion of the two metals.
- o C: difference in electrical resistance of the two metals.

355: (Q99) A complete antenna system consists of which of the following components?

- A: A feeder line, a coupling device, and an antenna.
- o B: An antenna, a transmission line, and a receiver.
- o C: A feeder, a coupling device, and a transmitter.

356: (Q492) The aircraft radio equipment which emits on a frequency of 4400 MHz is the:

- o A: weather radar.
- B: radio altimeter.
- o C: primary radar.

357: (Q234)Conditioned air is...

- o A: oxygen added.
- o B: moisture removed.
- C: temperature and pressure adjusted.

358: (Q671) The flight data recorders must preserve the required data of the last:

- o A: 48 hours of operation.
- o B: 30 minutes of operation.
- C: 25 hours of operation.

359: (Q634) A force applied to the spinning axis of a gyro is precessed:

- o A: through an angle equivalent to $15.04^\circ \times \sin \lambda$ (latitude).
- B: through 90° in the direction of rotor spin.
- o C: through 90° in the direction of the force.

360: (Q500) ARINC 629 current mode couplers are

- A: inductive.
- o B: capacitive.
- o C: resistive.

361: (Q366) What is the main advantage of using compressed air over hydraulics or electrical systems?

- A: Compressed air is lightweight and since no return system is required, weight is saved.
- o B: 3000 PSI (210 bar) is at all times available, even with small leaks.
- o C: Pneumatic operations are almost 100 percent efficient, with only negligible loss due to air friction.

362: (Q224) The heat exchanger in a turbo-fan system is cooled by...

- o A: air bled from the main cabin supply duct.
- B: ambient ram air.
- o C: engine bleed air or blower air.

363: (Q738) 'Some LRMs (Line Replaceable Modules) from the Integrated Modular Avionics communicate with each other through the ADCN (Avionics Data Communication Network) by the means of communication technology developed from a non-aeronautical standard.' This technology is called....

- o A: Automatic Dependent Surveillance Broadcast (ADS-B).
- o B: Controller Pilot Data Link communications (CPDLC).
- C: AFDX (Avionics Full Duplex Switched Ethernet).

364: (Q460) In an Autoland, autothrottle is disengaged

- o A: manually after landing.
- o B: after a fixed period of the time after landing.
- C: after reverse thrust is applied.

365: (Q615) When OAT increases what happens to a helicopter operating ceiling?

- o A: No effect.
- B: Decrease.
- o C: Increase.

366: (Q107) A squelch circuit disables the receiver output,

- o A: when satcom is selected.
- o B: when a SELCAL is received from ground stations equipped with a coding device.
- C: when no signals are being received so preventing noise being fed to the crew headsets between ground transmissions.

367: (Q333) When operating a windscreen wiper on the ground, make sure to....

- o A: use slow wiper only.
- o B: place soft cloth between blade and window.
- C: use water as lubricant when operating.

368: (Q254) Ditching control is used for.....

- o A: rapidly aircraft depressurisation.
- o B: deploying life rafts.
- C: closing all valves and inlets.

369: (Q177) Which of the following statements about the ram air turbine is false?

- o A: The RAT can sometimes also supply hydraulic power.
- B: The RAT can deploy automatically on the ground.
- o C: The RAT can be deployed manually.

370: (Q401) On aircraft an auto land during auto flare the auto throttle will

- o A: reverse thrust.
- o B: control throttle for a IAS.
- C: retard the throttle.

371: (Q578) Density errors are the result of variations in atmospheric....

- o A: temperature only.
- o B: pressure only.
- C: pressure and temperature.

372: (Q705) Information from a sensor to a display is provided electronically to the processing unit, commonly called a.....

- o A: video graphics card.
- o B: video card.
- C: symbol generator.

373: (Q30) An aircraft....

- o A: has more than one critical mach number on the wing only.
- B: has more than one critical mach number on different parts of the aircraft.
- o C: has only one critical mach number.

374: (Q238) A cabin humidifier is operated....

- A: at high altitudes.
- o B: on the ground.
- o C: at low altitudes.

375: (Q764) Which system enables aircraft to be accurately tracked by air traffic controllers and other pilots without the need for conventional radar?

- A: ADS-B (Automatic Dependent Surveillance Broadcast).
- o B: FANS (Future Air Navigation System).
- o C: Mode S transponder.

376: (Q308) A hydraulic accumulator is charged with initial air pressure of 1000 PSI . When the hydraulic system pressure of 3000 PSI is reached, the air pressure is ...

- o A: 4000 PSI.
- B: 3000 PSI.
- o C: 1000 PSI.

377: (Q605) An air data computer (ADC) obtains altitude from....

- A: Barometric data from static source.
- o B: GPS Satellite.
- o C: Radio Altimeter.

378: (Q399) What is the controlling factor in the automatic flare mode?

- A: Radio altimeter.
- o B: Localizer signal.
- o C: Decision height.

379: (Q573) During a walk around inspection, you observe covers over the pitot probes. Which items will be affected if the covers are not removed?

- o A: Airspeed, altimeter and autopilot.
- o B: Flight recorder, autopilot, vertical speed indicator and airspeed.
- C: Flight recorder, airspeed and autopilot.

380: When activated, the ELT transmits : 1. a standard swept tone on 121.5 MHz. 2. a standard swept tone on 243.0 MHz. 3. a 5 watt encoded digital message to the COSPAS/SARSAT satellite system. 4. a 24 bit address through the Mode S transponder.

- A: 1, 2 and 3.
- o B: 1 and 4.
- o C: 1, 2 and 4.

381: (Q264) Which of the following areas in an aircraft would only have a smoke detection system and no extinguishing system?

- o A: Cargo bay.
- o B: Engines.
- C: Avionics bay.

382: (Q569) Pitot pressure is a combination of:

- o A: dynamic pressure minus pitot pressure.
- B: static pressure and dynamic pressure.
- o C: static pressure and position error.

383: (Q5) A jet aircraft equipped with inboard and outboard ailerons is cruising at its normal cruise Mach number. Which of the following conditions is correct?

- A: only the inboard ailerons are active.
- o B: the inboard and outboard ailerons are active.
- o C: only the outboard ailerons are active.

384: (Q650) The principle of operation of the turn and bank indicator is best described as:

- o A: an earth gyro in which a calibrated spring ensures the tilt of the gyro is proportional to the aircraft rate of turn.
- o B: a single gimbal gyroscope whose primary precession is opposed by a spring which, in turn, produces a second precession equal and opposite the aircraft rate of turn.
- C: a single gimbal gyroscope in which a spring, opposing the primary precession, in turn produces a secondary precession equal to the aircraft rate of turn.

385: (Q594) If an aircraft were to climb after suffering a pitot blockage, the ASI would apparently:

- A: over-read, indicating an increase in speed.
- o B: under-read, indicating a decrease in speed.
- o C: show no change at all.

386: (Q113) Operation of an ELT.... 1. is automatic on impact by a 'G' force switch in the transmitter.
2. can be done through a remote switch in the cockpit. 3. can be done by a switch on the unit itself.
4. can be turned off with the switch on the case.

- o A: 1, 2 and 4.
- o B: 2, 3 and 4.
- C: 1, 2, 3 and 4.

387: (Q14) How does a delta wing aircraft move about the pitch and roll axis?

- A: elevons.
- o B: ailerons.
- o C: elevators.

388: (Q584) An aircraft takes off from an airfield 126 ft AMSL with a QFE of 994 hPa set. During flight, a regional QNH of 999 hPa is set. If the aircraft were to return to the departure point, where there had been no pressure change, without re-setting the altimeter, the height reading on landing would be:

- A: 150 ft
- o B: 126 ft
- o C: 276 ft

389: (Q750) Data can be transferred wirelessly from the In-flight Entertainment system on the aircraft to a terminal receiving station on the ground through....

- A: the use of the GSM Cell Data Mode (CDM), also referred to as Cell Modem (CM).
- o B: the ATIS (Automatic Terminal Information Service).
- o C: the ACR (Avionics Communication Router).

390: (Q228) What is the benefit of injecting water in the ram air duct?

- o A: Make the cabin air less dry.
- B: Improve the efficiency of the heat exchanger.
- o C: Cool the air cycle machine.

391: (Q437) Auto throttle can hold: 1. speed. 2. flight path. 3. altitude. 4. Mach. 5. EPR / N1. 6. Attitude. The combination regrouping all the correct statements is:

- A: 1, 4 and 5.
- o B: 1, 2, 3 and 4.
- o C: 1, 2 and 6.

392: (Q239) In an airconditioning system, the purpose of the condenser is to condense water in the air before it goes to the....

- A: water extractor.
- o B: bypass valve.
- o C: heat exchanger.

393: (Q498) An ARINC 429 binary coded decimal data word occupies bits

- o A: 1 to 8
- B: 11 to 28
- o C: 11 to 29

394: (Q462) In triplex autoland system failure of one channel will

- o A: disconnect the failure channel and continue with a manual approach.
- B: disconnect the failure channel and continue autoland approach.
- o C: disconnect all channels.

395: (Q458) If a fault is detected during an autoland approach the system will totally disconnect if it is a

- A: Simplex system.
- o B: Triplex system.
- o C: Duplex system.

396: (Q358) In which type of aircraft is liquid oxygen used?

- o A: Most large passenger aircraft.
- B: Military aircraft.
- o C: Aircraft flying at very high altitudes.

397: (Q102) The VHF (very high frequency) range of the radio spectrum is the band extending from

- A: 30 MHz to 300 MHz.
- o B: 3 to 30 GHz
- o C: 300 to 3000 MHz.

398: (Q612) Position error:

- o A: will depend solely on the attitude of the aircraft.
- B: may be reduced by the fitting of static ports.
- o C: will usually decrease with an increase in altitude.

399: (Q735) Which network system routes data between the airplane and ground networks and stores airline data and applications?

- A: IMA (core network).
- o B: IDN.
- o C: ATIS.

400: (Q517) Doppler operates on the principle that .(1)..between a transmitter and receiver will cause the received frequency to .(2)..if the transmitter and receiver are moving .(3)..

- o A: (1) the distance - (2) increase - (3) at the same speed.
- o B: (1) apparent moving - (2) decrease - (3) together.
- C: (1) relative motion - (2) decrease - (3) apart.

401: (Q410) A yaw damper will apply rudder proportional to

- A: rate of yaw.
- o B: attitude of aircraft.
- o C: amount of aircraft disturbance.

402: (Q229) What is the function of a pack control valve?

- o A: Control the airflow out of the cabin.
- o B: Control the outlet temperature of the pack.
- C: Control the air flow into the cabin.

403: (Q268) How is avionics smoke detected?

- o A: By smoke detectors in the avionics boxes.
- o B: By carbon monoxide detectors in the avionics bay.
- C: By sampling the air extracted from the avionics compartment racks.

404: (Q591) During an approach to land at an airfield with the pitot source blocked, the Air Speed Indicator will show:

- o A: an increasing over read.
- o B: No change in the indication.
- C: an increasing under read.

405: (Q611) A static port is used to measure:

- o A: dynamic pressure plus pitot pressure.
- B: atmospheric pressure.
- o C: dynamic pressure minus pitot pressure.

406: (Q111)Emergency locator transmitters are self-contained, self-powered radio transmitters, designed to transmit a signal on the international distress bands of (civilian) and (military).

- o A: 30 MHz - 300 MHz
- B: 121.5 MHz - 243 MHz
- o C: 108.10 MHz - 112 MHz

407: (Q369) What is important about the air entering a dry air pump?

- A: It must be filtered.
- o B: It must be pressure controlled.
- o C: It must be temperature controlled.

408: (Q386) Autopilot disengagement is....

- o A: an aural warning only.
- o B: a caution light and an aural warning.
- C: an aural warning and flashing light.

409: (Q8) In a Frise aileron control system....

- o A: the down-going aileron moves through a greater angle than the up- going aileron.
- B: the up-going aileron produces increased drag.
- o C: the down-going aileron allows air to spill from below the wing to the upper surface of the ailerons.

410: (Q150) The Flight Management Computer (FMC) position is:

- A: the computed position based on a number of sources (IRS, Radio, ILS, GPS etc).
- o B: another source of aircraft position; it is independent of other position sources (IRS, Radio, ILS etc).
- o C: the actual position of the aircraft at any point in time.

411: (Q493) A Radar altimeter system measures altitude....

- o A: in combination with GPS-satellites
- o B: in relation to sea level.
- C: above terrain.

412: (Q337) What is a stripe or mark extending from the rim of a wheel onto the tire?

- o A: Indicates the tire is a high-pressure type.
- o B: A balance mark.
- C: A creep mark.

413: (Q763) Data on the USB keys (for data loading) is stored under the ...

- o A: ARINC 629 format.
- B: ARINC 615A format.
- o C: ARINC 429 format.

414: (Q669) When accelerating on an easterly heading in the northern hemisphere, the magnet system of a direct reading compass will:

- o A: Turn anti-clockwise, indicating an apparent turn towards South.
- o B: Turn clockwise, indicating an apparent turn towards North.
- C: Turn anti-clockwise. indicating an apparent turn towards North.

415: (Q61) What are water lines?

- o A: Measurements from the centre line.
- B: Horizontal measurement lines.
- o C: Vertical measurement lines.

416: (Q241) Which of the following modes of pressurization places the highest load demands on the aircraft structure?

- o A: Unpressurized.
- o B: Constant-differential pressure.
- C: Isobaric mode.

417: (Q729) An airborne Ethernet electrical cable (AFDX) is

- A: equipped with 4 pins Quadrx connectors.
- o B: equipped with 8 pins RJ45 connectors.
- o C: equipped with 4 pins RJ45 connectors.

418: (Q441) During flare mode autothrottle will

- o A: disconnect autothrottle.
- o B: select reverse thrust.
- C: retard throttles to idle.

419: (Q123) The MIDDLE MARKER of an Instrument Landing System (ILS) facility is identified audibly and visually by a series of:

- o A: dots and a white light flashing.
- o B: dashes and an amber light flashing.
- C: alternate dots and dashes and an amber/yellow light flashing.

420: (Q32) The tail rotor

- o A: is not subject to dissymmetry of lift.
- o B: produces a force in the same direction as torque reaction.
- C: produces a force opposing torque reaction.

421: (Q632) The compensator in a fuel tank measures....

- o A: fuel quantity.
- B: capacitance of fuel transmitter.
- o C: specific gravity of fuel.

422: (Q162) Which type of battery can experience cell reversal and how can it be prevented?

- o A: Lead-acid battery. Prevented by fast charging battery.
- o B: NiCad battery. Prevented by always fully discharging the battery.
- C: NiCad battery. Prevented by never fully discharging the battery.

423: (Q378) The definition of fail operational is the ability of a system to

- A: continue to control after any first fault.
- o B: disconnect and leave the aircraft in trim.
- o C: disconnect but leave the aircraft out of trim.

424: (Q483) A frequency used by airborne weather radar is:

- o A: 1213 MHz.
- B: 9.375 GHz.
- o C: 8800 MHz.

425: (Q599) The Machmeter has two capsules:

- o A: one responds to altitude, the other to density.
- B: one responds to altitude, the other to airspeed.
- o C: 'one responds to airspeed, the other to the local speed of sound.'

426: (Q155) What is the minimum number of satellites required for a Satellite-Assisted Navigation System (GNSS/GPS)?

- o A: 2
- o B: 3
- C: 4

427: (Q13) Which control surfaces provide directional and pitch control?

- o A: tailerons.
- o B: elevons
- C: ruddervators.

428: (Q370) What regulates the cooled air coming out of the pre-cooler?

- o A: The FAMV (Fan Air Modulating Valve).
- o B: The HPSOV (High Pressure Shut-Off Valve).
- C: The PRSOV (Pressure Regulating and shut-off Valve).

429: (Q586) The IVSI is:

- o A: only unreliable at angles of bank exceeding 55°.
- o B: Unreliable in pitch but reliable in roll.
- C: Unreliable in unbalanced turns/angles of bank exceeding 40°.

430: (Q690) The level of alert for conditions that require immediate flight crew awareness and immediate flight crew response is..... Loss of cabin pressure or an engine fire are typical examples.

- o A: alert message.
- o B: a caution.
- C: a warning.

431: (Q297) How is the amount of Fuel indicated to the pilots?

- o A: Height (cm or inch)
- B: Weight (Kgs or Lbs)
- o C: Volume (m3)

432: (Q218) An air-to-air heat exchanger is provided to....

- A: reduce the air supply temperature.
- o B: provide an emergency ram air supply.
- o C: increase the air supply temperature.

433: (Q44) The primary purpose of the tail rotor is

- A: to counteract torque.
- o B: to give lateral stability.
- o C: to give directional control.

434: (Q251) When operating the outflow valve in manual/emergency mode, which motor is used?

- A: The DC motor.
- o B: The AC motor.
- o C: Both AC and DC motors.

435: (Q64) How should all electronic equipment bondings be installed in the aircraft structure?

- o A: With a low current path to the airframe structure.
- B: With a low impedance path to the airframe structure.
- o C: With a high impedance path to the airframe structure.

436: (Q341) Why must the nose wheel assembly be centered before retraction?

- A: Damage to the gear or frame structure may occur if it is not centered.
- o B: The tires may be damaged on landing if the nose wheel is not centered

- o C: The aircraft may swerve on the next landing if the nose wheel is not centered.
- 437: (Q574) Which instruments are connected to the aircraft pitot-static system?
- o A: turn coordinator, cabin altimeter and cabin rate-of-change indicator.
 - B: vertical speed indicator, altimeter and airspeed indicator.
 - o C: turn-and-slip indicator, airspeed indicator and directional gyro (air operated).
- 438: (Q159) The electrolyte in a NiCd battery is?
- o A: Lithium based.
 - B: Alkaline based.
 - o C: Acid based.
- 439: (Q136) Which one of the following inputs to an Area Navigation System (R-NAV) comes from an external, not on-board, system?
- A: VOR/DME radial/distance.
 - o B: Inertial Navigation System (INS) position.
 - o C: Magnetic heading.
- 440: (Q101) Attenuation is...
- o A: the combination of multiple radio signals.
 - B: the loss of power of a radio signal.
 - o C: the increase of power of a radio signal.
- 441: (Q731) For IMA, a faster and duplex data communication protocol was required than the ARINC 429 standard. The new standard is ..
- o A: ARINC 429 duplex.
 - o B: AFDX (Avionics Full Duplex).
 - C: ARINC 664.
- 442: (Q666) Hard iron is the name given to a metal which:
- o A: Is easy to magnetize and loses its magnetism easily.
 - o B: Is difficult to magnetize and loses its magnetism easily.
 - C: Is difficult to magnetize and retains its magnetism.
- 443: (Q130) Concerning conventional and Doppler VORs (DVOR), which of the following is correct?
- o A: The DVOR will always have a 'D' in the ident.
 - B: It is not possible for the instrumentation display to determine which type is being used.
 - o C: The DVOR has a higher audio ident tone than the standard VOR.
- 444: (Q422) Automatic steering of the aircraft after touch down is affected by
- o A: the airfield marker beacon.
 - B: the runway localiser.
 - o C: the area navigation system.
- 445: (Q258) What protects the aircraft from over-pressurization?
- o A: The outflow valve.
 - B: The positive pressure relief valve.
 - o C: Cabin pressure controller.

446: (Q184) Which of the following is NOT part of a three-unit voltage regulator?

- o A: Reverse current relay.
- o B: Current limiter.
- C: Open phase protection.

447: (Q119) On an ILS approach what will cause the aircraft to fly onto the beam?

- o A: Radio deviation.
- B: Course deviation.
- o C: Glideslope deviation.

448: (Q523) An aircraft with two passenger decks with more than 100 seats per deck is equipped with....

- o A: 3 megaphones.
- B: 4 megaphones.
- o C: 1 megaphone.

449: (Q365) Which indication of a used chemical oxygen generator is provided?

- o A: The pressure indicator will be in the red zone.
- o B: No indication, only by weighing the oxygen generator the status can be determined.
- C: A change of colour of a band of thermal paint around the case.

450: (Q391) What controls in a closed loop system the flight control movement?

- o A: An amplifier.
- B: A servomechanism.
- o C: A rate gyro.

451: (Q201) Which lights can be used to detect ice build-up?

- o A: Runway turn-off lights.
- o B: Position lights.
- C: Wing scan lights.

452: (Q226) What supplies in a turbo fan cold air system, the heat exchanger cooling air?

- o A: Air bled from cabin air supply duct.
- o B: Air bled directly from engine or through blower.
- C: Fan drawn ambient air.

453: (Q448) When an automatic landing is interrupted by a go-around: 1. The auto throttle reacts immediately upon the pilot action on TO/GA switch in order to recover the maximum thrust. 2. The autopilot monitors the climb and rotation of the airplane. 3. The autopilot retracts the landing gear and reduces the flap deflection in order to reduce the drag. 4. The pilot performs the climb and the rotation of the airplane. 5. The pilot retracts the landing gear and reduces the flap deflection in order to reduce the drag. The combination regrouping all the correct statements is:

- A: 1, 2, 5.
- o B: 1, 3, 4.
- o C: 1, 2, 3.

454: (Q223) When the ram air passes through the primary heat exchanger, where does the ram air in a turbo-fan cold air system flows to?

- o A: Inter cooler or secondary heat exchanger.
- B: Via large fan to ram air outlet.
- o C: Turbine.

455: (Q661) The Ground Proximity Warning systems mode 3 is activated when

- o A: The barometric descent rate is excessive with respect to the aircraft height above the terrain.
- o B: The aircraft is flying into rising terrain.
- C: An excessive height loss is experienced after take-off during go-around.

456: (Q125) The BFO (Beat Frequency Oscillator) selector on an ADF receiver is used to....

- A: hear the IDENT of some NDB stations radiating a continuous wave signal.
- o B: find the loop 'null' position.
- o C: display the ident on display.

457: (Q772) A passenger with a laptop can access to e-mail and internet applications in the...

- A: Communication & Cabin Domain.
- o B: Avionics Domain.
- o C: Flight Operations Domain.

458: (Q767) Recording capability of aircraft parameters is part of the ...

- A: Avionics Domain.
- o B: Flight Operations Domain.
- o C: Communication & Cabin Domain.

459: (Q564) Pressure measured from atmospheric pressure is called....

- A: gauge pressure.
- o B: relative pressure.
- o C: absolute pressure.

460: (Q514) How do you call the waves depicted in the figure with an A?

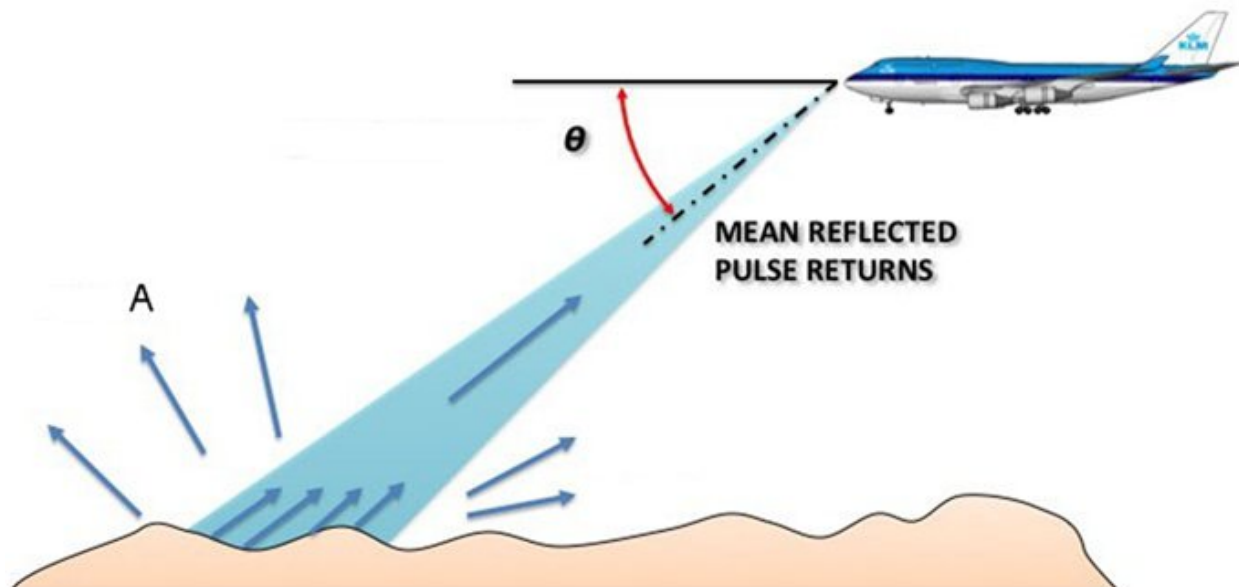

- A: Scattered waves.

- o B: Deflected waves.
- o C: Depression waves.

461: (Q648) A faulty rate of turn and bank indicator in a general aviation aircraft may be checked by a pilot in the air by....

- A: timing an indicated rate one turn.
- o B: comparing the indication with the attitude indicator.
- o C: slipping the aircraft right or left.

462: (Q651) The errors of a DGI are: 1. Earth rate. 2. Transport wander. 3. Banking when pitched up. 4. Annual movement of poles. 5. Mechanical problems.

- A: 1, 2, 3 & 5.
- o B: 2, 3 & 5.
- o C: 3, 4 & 5.

463: (Q424) When the bank angle limit is applied to the autopilot, it means

- o A: maximum rudder deflection.
- B: the max roll angle that can be demanded by the autopilot.
- o C: the max aileron angle that can be commanded.

464: (Q197) In the differential protections circuit in the figure below, what type of transformers would be TRANSFO 1 and TRANSFO 2?

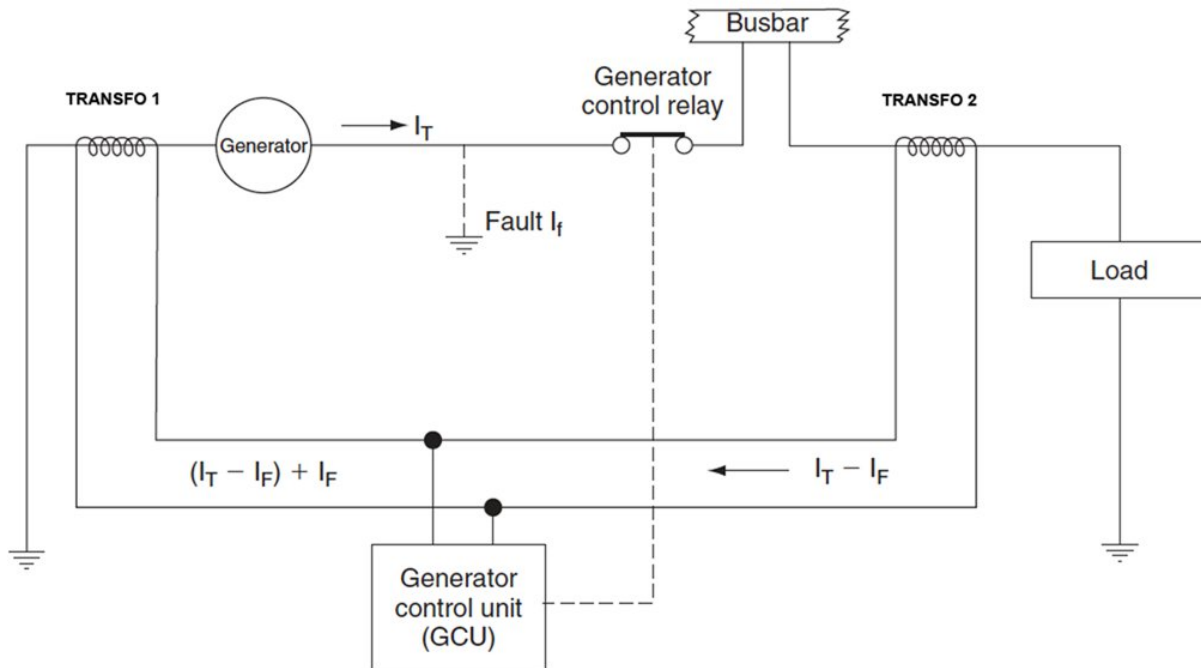

- o A: TRANSFO 1 is a current transformer, TRANSFO 2 is a voltage transformer
- o B: Both are voltage transformers
- C: Both are current transformers

465: (Q312) A constant volume hydraulic system uses a(n).... to relieve pressure in the system when no services are being used?

- o A: Pressure relief valve.
- o B: return line back to pump.
- C: ACOV (Automatic Cut Out Valve).

466: (Q196) Where in the circuit would a fuse be installed?

- o A: As close to the unit to be protected as much as possible.
- o B: Where access to replace the fuse is easiest.
- C: As close to the power source as possible.

467: (Q537) What is the fundamental difference between a trim tab and a servo tab?

- o A: The functioning of a trim tab is based on aerodynamic balancing, a servo tab in general is adjusted via a screw jack.
- o B: A trim tab is automatically adjusted when the particular control surface moves, a servo tab is moved independently of the particular control surface.
- C: The purpose of a trim tab is to reduce continuous stick force to zero, a servo tab only reduces stickforce.

468: (Q342) When the landing gear is locked up, the cockpit indicator shows ...

- o A: green light.
- B: no indication.
- o C: red light.

469: (Q433) Auto-throttle engaged mode can be checked by the pilot, using:

- A: primary flight display.
- o B: thrust control computer.
- o C: position of throttles.

470: (Q743) What are the three functional domains of IMA (Integrated Modular Avionics)?

- o A: Flight, navigation and systems.
- B: Cockpit, cabin and utilities.
- o C: Ground, flight and transit.

471: (Q427) The application of normal forces on the control column with the autopilot engaged is called....

- o A: parallel connected system.
- B: control wheel steering.
- o C: touch control steering.

472: (Q550) What are ground spoilers used for?

- o A: To assist the aircraft when go around is selected on ground.
- B: To dump lift.
- o C: For steering commands while taxiing.

473: (Q394) In the FMS vertical navigation (V NAV) climb mode the throttles are used for

- o A: controlling to a maximum thrust.
- B: maintaining a computed EPR.
- o C: correction minor speed deviations.

474: (Q710) Data loading is a....

- A: reading or writing information facility.
- o B: reading information facility.
- o C: writing information facility.

475: (Q348) What controls the nose wheel steering on a large modern aircraft?

- A: A separate pilot operated control.
- o B: The control column.
- o C: Differential braking

476: (Q147) To know the valid data base on the FMS

- o A: perform a BITE check.
- B: call up the relevant page on the CDU.
- o C: call up the relevant current status.

477: (Q645) A leaking case on an air-driven turn and bank indicator will cause:

- o A: no appreciable error.
- o B: the turn to over-read.
- C: the turn to under-read.

478: (Q322) When is a 'hot rod' type of ice detector switched on?

- o A: when in the air.
- o B: all the time.
- C: when selected by the crew.

479: (Q200) When connecting external power, what prevents the application of reverse polarity to a DC powered aircraft?

- o A: An irreversible external power connector (fool proof).
- o B: A reverse current switch.
- C: A reverse polarity diode.

480: (Q501) ARINC 629 data bus is

- o A: two buses, unidirectional.
- B: one bus, bi-directional data flow.
- o C: two buses, bi-directional data flow.

481: (Q252) What places the pressure controller in the depressurisation mode after landing?

- A: Engines at idle and the landing gear compressed.
- o B: Engines at idle.
- o C: Landing gear compression.

482: (Q598) Machmeter readings are subject to:

- o A: instrument and compressibility errors.
- B: instrument and pressure errors.
- o C: compressibility and position errors.

483: (Q222) What is the function of the turbine in an air cycle machine? The turbine drives the compressor to....

- o A: pressurise aircraft.
- o B: decrease temperature.
- C: increase temperature.

484: (Q530) How does the IFES (In-Flight Entertainment System) send audio and video signals?

- A: A standard 100 Mbit/s fast Ethernet LAN.
- o B: Fibre optics.
- o C: A standard 1 Gbit/s fast Ethernet LAN.

485: (Q153) GPS sends different codes, what are these codes?

- A: C/A code and P (precision) code.
- o B: C/A (coarse/acquisition) code only.
- o C: P code only.

486: (Q504) ACARS messages are sent from the aircraft via:

- o A: an UHF communication transceiver.
- B: a VHF communication transceiver.
- o C: GNSS.

487: (Q527) The means of interacting with cabin management computers may involve using remote control devices. What do these remote devices use for communication?

- o A: Ethernet.
- o B: VLF.
- C: Either infrared (IR) or radio frequency (RF).

488: (Q609) When the moisture separator is purged in a pneumatic system, it dumps

- o A: the system between vacuum pump and regulator valve.
- B: just the moisture trap.
- o C: the whole system.

489: (Q663) The Ground Proximity Warning systems mode 5 is activated when

- o A: An unsafe clearance situation is experienced, with the aircraft not in the landing configuration.
- o B: An excessive height loss is experienced after take-off during go-around.
- C: When the aircraft is significantly below its ILS glidepath.

490: (Q274) How can you determine if the lavatory fire bottle has been discharged?

- o A: By the temperature indicator strip.
- B: By weighing it.
- o C: By reading the pressure gauge on the bottle.

491: (Q244) The constant-differential pressure operation mode cabin is when the cabin altitude....

- A: is maintained at a constant amount above the outside ambient air pressure.
- o B: remains constant as the flight altitude changes.
- o C: remains the same as the flight altitude.

492: (Q566) In a mechanical oil pressure gauge the sensing element is:

- A: a bourdon tube.
- o B: a helical bimetallic spring.

o C: a liquid capillary.

493: (Q443) When GA is initiated?

- o A: Auto throttle disengages at 2000 ft/min rate and wings will level.
- B: Auto throttle remains engaged giving correct G/A thrust.
- o C: Auto throttle remains engaged allowing pilot to control the throttles.

494: (Q62) Fuselage station numbers are measured from the front of the aircraft. In what unit are they measured?

- A: inches.
- o B: feet and inches.
- o C: feet.

495: (Q204) What kind of light is used as cabin flood lighting?

- o A: Spot lights
- o B: Incandescent light bulbs.
- C: Fluorescent tubes.

496: (Q762) What is the main protocol of communication in the open world?

- o A: ARINC 629.
- B: Ethernet.
- o C: ARINC 429.

497: (Q219) The aircraft air conditioning system keeps the....

- A: cabin pressure at 8000 ft cabin altitude.
- o B: cabin altitude (pressure) at 10.000 ft.
- o C: humidity high in the cabin.

498: (Q298) How is the fuel quantity measured in the manual way?

- o A: The electrical resistance between two points.
- o B: From the top of the wing visual.
- C: With dipstick.

499: (Q740) This is a.... (See the figure)

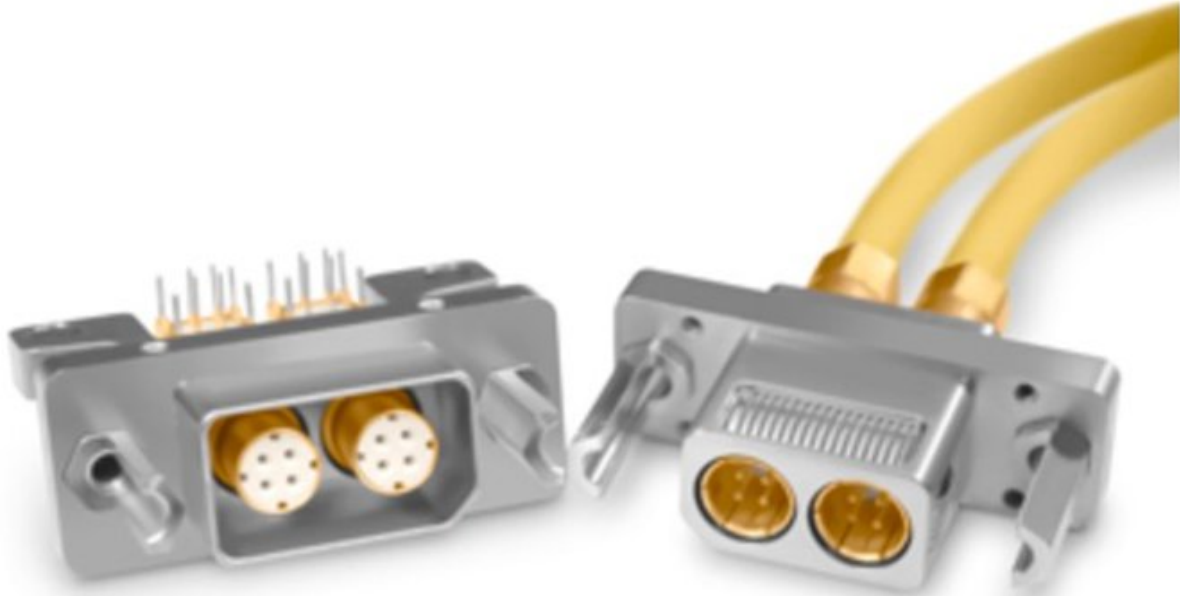

- A: Quadrax connector.
- o B: Coaxial connector.
- o C: LC connector (fibre optic).

500: (Q543) Make the best choice: The employment of active control technology presents numerous advantages, namely: 1. more stable aircraft. 2. more comfortable flight. 3. better fuel consumption. 4. possible to fly the aircraft beyond its design limitations.

- o A: 2, 3 and 4.
- o B: 1, 2 and 4.
- C: 1, 2 and 3.

501: (Q395) The GA mode is usually initiated by....

- A: pressing a button on thrust levers.
- o B: pressing a button on the autopilot control panel.
- o C: making a selection on the mode control panel.

502: (Q522) The capacity of the emergency batteries are capable of providing emergency lighting for a period of at least ...

- o A: 1 minute.
- B: 10 minutes.
- o C: 1 hour.

503: (Q180) When will the hydraulic motor generator (HMG) supply power?

- o A: Manually, when the pilot switches it on after both main AC buses lose power.
- B: Automatically when both main AC buses lose power.
- o C: Automatically when the main battery is discharged.

504: (Q143) What is an FMC?

- o A: A flight management inertial reference system.
- B: A flight management computer.
- o C: An autopilot/flight director system.

505: (Q583) In a servo-assisted altimeter, the secondary winding from the E-bar provides an electrical current direct to the:

- o A: two phase motor.
- o B: capsule stack.
- C: amplifier of the servomotor..

506: (Q212) Why does the engine bleed air supply come from the low and high stage of the compressor?

- o A: If the low pressure stage supply fails, the high stage takes over.
- o B: Some bleed air systems will use only the low pressure stage, others will use the high stage.
- C: If the low pressure stage cannot supply enough air, the high stage will be used.

507: (Q769) Which system (of the core network system) collects, correlates, stores and shows fault information for most airplane systems.

- A: central maintenance computing function.
- o B: crew information system.
- o C: common data network (CDN).

508: (Q505) The continuous broadcast of recorded non-control information in busier terminal areas (i.e. Airport) is called

- o A: ACARS
- o B: SITA
- C: ATIS

509: (Q164) What product does the sump jar contain in the vent line of a lead-acid battery installation?

- o A: Distilled water.
- B: Bicarbonate of soda and water.
- o C: Boric acid.

510: (Q421) An automatic pitch trim system employs a separate pitch trim servomotor which operates....

- o A: as a stand-alone system.
- o B: in series with the autopilot pitch control servo.
- C: in parallel with the autopilot pitch control servo.

511: (Q327) The inflatable tube of the de-icer boots is made of ...

- o A: natural rubber.
- B: rubberised fabric.
- o C: synthetic rubber.

512: (Q659) The Ground Proximity Warning systems mode 1 is activated when

- A: The barometric descent rate is excessive with respect to the aircraft height above the terrain.
- o B: An excessive height loss is experienced after take-off during go-around.
- o C: The aircraft is flying into rising terrain.

513: (Q734) The core network system has ...

- o A: an ethernet network and an crew information network.
- B: an open data network and an isolated data network.
- o C: an open data network, an isolated data network and an avionics network.

514: (Q363) How can you see if a chemical oxygen generator has been expended?

- o A: By a pop-out indicator.
- B: By a coloured band of thermal paint.
- o C: By a pressure indicator.

515: (Q11) Which flight control surfaces does have a Flaperon function?

- o A: flaps and elevators.
- o B: flaps and speed brakes.
- C: flaps and ailerons.

516: (Q597) If the static source becomes blocked with ice and the aircraft descends rapidly, the Machmeter will:

- A: over-read.over-read.
- o B: under-read.under-read.
- o C: not be subject to any errors because of the dual capsule.not be subject to any errors because of the dual capsule.

517: (Q2) The axes of an aircraft by definition must all pass through the:

- A: centre of gravity (CG).
- o B: aircraft datum.
- o C: centre of pressure (CP).

518: (Q600) A transport airplane has to be equipped with an altitude warning device. This system will warn the crew about : 1. getting close to the preselected altitude, during both climb and descent; 2. getting close to the preselected altitude, during climb only; 3. the loss of altitude during take-off or missed approach; 4. a wrong landing configuration; 5. a variation higher or lower than a preselected altitude. The combination regrouping the correct statements is:

- A: 1 and 5
- o B: 1, 3 and 4.
- o C: 2

519: (Q146) In the FMS vertical navigation (VNAV) climb mode the throttles are used for

- o A: correction for minor speed deviations.
- o B: controlling to a maximum thrust.
- C: maintaining a computed EPR.

520: (Q329) What is the source of air for the windscreen pneumatic rain removal system?

- A: engine bleed air.
- o B: a dedicated pneumatic motor to drive windscreen wipers.
- o C: the venturi windscreen duct.

521: (Q473) A 'resolution advisory' (RA) is represented on the display system of the TCAS 2 (Traffic Collision Avoidance System) by a....

- o A: blue or white full lozenge.
- o B: red full circle.
- C: solid red square.

522: (Q447) On an autopilot coupled approach, GO AROUND mode is engaged:

- A: By the pilot pushing a button located on the throttles.
- o B: If the aircraft reaches the decision height selected on the radio altimeter at a higher speed than the one selected.
- o C: By the pilot selecting G.A. mode on the thrust computer control panel.

523: (Q465) During a CAT 2 ILS automatic approach, the source for altitude information is the

- o A: basic altitude capsule stack.
- o B: mode comparator sensor.
- C: radar altimeter which becomes effective below about 2500 feet.

524: (Q166) What is the purpose of a rectifier?

- o A: Control the output voltage of a parallel wound generator.
- o B: Convert the DC output into AC.
- C: Convert the AC output to DC.

525: (Q703) The Primary Flight Display (PFD) displays information dedicated to:

- A: piloting.
- o B: engines and alarms.
- o C: systems.

526: (Q558) What is the effect of a single failure of a fly-by-wire system?

- A: It has no effect on the aircraft's operation.
- o B: It will limit the flight profile.
- o C: It will reduce the operational height and speed.

527: (Q283) When should you use water-type portable fire extinguishers?

- o A: Water-type portable extinguishers are perfect solid combustible materials even metal fires. (ex: brakes and magnesium wheels). Do not use them on flammable liquid fires.
- B: Water-type portable extinguishers are best for solid combustible fires (paper, fabrics, wood etc.). Never use them on electrical or flammable liquid fire.
- o C: Water-type portable extinguishers can be used for every fire.

528: (Q1) About which axis does rolling occur?

- A: longitudinal axis.
- o B: lateral axis.
- o C: vertical axis.

529: (Q148) If one FMS fails in a dual system

- o A: system operation will not be affected.
- B: FMS display transfers data automatically from serviceable computer.
- o C: FMS CDU on fail side goes blank.

530: (Q293) To decrease the amount of unusable fuel, what is fitted to the engine feed manifold?

- o A: NACA duct.
- B: drain check valve.
- o C: float valve.

531: (Q332) On large transport aircraft, the windshield wiper system is....

- o A: one system for both sides but with the same power source.
- B: independent on each side with different power sources.
- o C: independent on each side but with the same power source.

532: (Q595) IAS is adjusted to CAS by the application of:

- A: instrument and pressure error.
- o B: compressibility error.
- o C: density error.

533: (Q314) What is the purpose of a shuttle valve?

- o A: preventing fluid loss from a leaking jack.
- B: change over from main to alternate system in the case of failure.
- o C: maintaining fluid pressure when the emergency system fails.

534: (Q454) If during autoland the LOC signal is lost at 400 ft in final approach

- A: go-around is initiated.
- o B: autoland is continued.
- o C: system degrades to CAT II.

535: (Q144) Which of the following is the FMS normal operating condition in the cruise?

- o A: LNAV only
- B: LNAV and VNAV.
- o C: LNAV or VNAV.

536: (Q350) Inadvertent retraction of an electronically controlled landing gear on the ground is....

- o A: always a danger after the ground locks have been removed.
- o B: not possible because the system is not powerful enough.
- C: prevented by the ground/air logic system.

537: (Q593) Which of the following is not an error associated with the ASI?

- A: Barometric pressure error.
- o B: Position error.
- o C: Compressibility error.

538: (Q472) TCAS 2 (Traffic Collision Avoidance System) uses for its operation:

- o A: only the replies from the transponders of other aircraft.
- B: both the replies from the transponders of other aircraft and the ground-based radar echoes.
- o C: only the echoes from the ground air traffic control radar system.

539: (Q216) What supplies the warm air in a bleed air air-conditioning system?

- o A: The engine exhaust heat.
- o B: The gas turbine exhaust.
- C: The compressor of the gas turbine engine.

540: (Q165) What is the dis-advantage of series wound generators?

- o A: When the aircraft electrical load increases, the output current increases.
- B: When the aircraft electrical load increases, the output voltage increases.
- o C: When the aircraft electrical load increases, the output voltage remains the same.

541: (Q533) When an aircraft fitted with spoilers is rolled to the left, what is the movement of those spoilers?

- A: Left spoiler is deflected up.
- o B: Left spoiler is deflected up and the right down.
- o C: Right spoiler is deflected down.

542: (Q227) Heating for pressure cabins is obtained from....

- o A: only by adding heat electrically to the air supply.
- B: air supply heated by adding hot bleed air.
- o C: air cycle machine.

543: (Q519) The Doppler Navigation System is based on....

- A: radar principles using frequency shift.
- o B: pulse shift transmission.
- o C: radio waves refraction in the ionosphere.

544: (Q248) The outflow of air from the cabin is regulated by

- A: outflow valves.
- o B: vent valve.
- o C: trim valve.

545: (Q481) Weather radar domes are protected from lightning strikes by

- o A: special conducting or non-conducting grease.
- B: bonding strips.
- o C: the use of special conductive paint.

546: (Q556) How can flutter be reduced?

- A: Mass balancing.
- o B: Servo tabs.
- o C: A horn balance.

547: (Q151) How many satellites are required for GNSS?

- A: 4
- o B: 8
- o C: 6 (90° apart)

548: (Q691) The following are time-critical warnings: 1. terrain awareness warnings. 2. overspeed warnings. 3. wind shear warnings. 4. TCAS resolution advisory. 5. low energy warnings. The combination regrouping all the correct time-critical warnings is:

- o A: 2, 3 and 4.
- B: 1, 2, 3, 4 and 5.
- o C: 1, 2 and 3.

549: (Q407) Which airplane behavior will be corrected by a yaw damper?

- o A: Spiral dive.
- B: Dutch roll.
- o C: Tuck under.

550: (Q719) The printer used in the cockpit is....

- o A: a laser printer.
- o B: an inkjet printer.
- C: a dot matrix printer.

551: (Q364) Where can you find a direct reading pressure gauge on an oxygen system?

- o A: On the oxygen system control panel.
- B: On the oxygen bottle.
- o C: On the flight deck.

552: (Q449) During an automatic landing, the aircraft descent rate is sensed by

- o A: pitch rate gyros.
- o B: vertical accelerometers.
- C: radio altimeters.

553: (Q334) On large aircraft, what are bogie type undercarriages used for?

- o A: Absorb increased landing shock.
- B: Spread the weight over a large area.
- o C: Prevent skidding.

554: (Q520) Exit signs must have ...

- A: red letters on a white electrically or self illuminated background.
- o B: white electrically or self illuminated letters on a black background.
- o C: black letters on a white electrically or self illuminated background.

555: (Q502) In an ARINC 429 wordstring, bits 1 to 8 represent the

- o A: source of message.
- o B: destination LRU address.
- C: information contained in the data word.

556: (Q476) On a TCAS 2 (Traffic Collision Avoidance System) the preventive 'resolution advisory' (RA) is a 'resolution advisory':

- o A: asking the pilot to modify effectively the vertical speed of his aircraft.
- B: that advises the pilot to avoid certain deviations from the current vertical rate but does not require any change to be made to that rate.
- o C: asking the pilot to modify the heading of his aircraft.

557: (Q549) In a turn, wing spoilers may be deployed....

- A: to assist the up going aileron.
- o B: in unison with both the up going and down going ailerons.
- o C: to act as an airbrake, interacting with the ailerons.

558: (Q617) A remote reading thermometer depends upon....to indicate changes in temperature.

- A: change of electrical resistance with temperature.
- o B: change of electrical capacitance with change in temperature.
- o C: change of electrical resistance of the two metals.

559: (Q71) Skin effect is most likely to occur:

- o A: at high power levels up to VHF.
- o B: in radar systems fed by rectangular waveguides.
- C: at the higher frequencies i.e. VHF and above.

560: (Q206) Who controls the 'no smoking' and 'fasten seat belts' lights?

- A: Pilot.
- o B: Flight attendant.
- o C: Passenger.

561: (Q134) Every dot on the localizer deviation scale is....

- o A: 5 nm from center line
- B: 1 nm from center line
- o C: 10 nm from center line

562: (Q654) The purpose of the flux-valve is:

- o A: To provide flux for the automatic slaving system.
- o B: To measure the strength of the earth's magnetic field.
- C: To sense the direction of the earth's magnetic field relative to the airplane.

563: (Q555) What eliminates Dutch roll?

- A: The yaw damper.
- o B: The Dutch Roll damper.
- o C: The differential ailerons.

564: (Q152) The space segment of GPS consists of a minimum of....

- o A: 27 satellites.
- o B: 21 satellites.
- C: 24 satellites.

565: (Q744) The passengers can listen to the selected audio and video channels by connecting a headset to ...

- A: the IFES RJU (Remote Jack Unit).
- o B: the IFES SEB (Seat Electronic Box).
- o C: the IFES SDU (In-Flight Entertainment System Smart Display Unit).

566: (Q717) Information to be printed is sent to the printer ...

- A: from the CMC (Central Maintenance Computer).
- o B: from the CDU (Control Display Unit).
- o C: from the FMC (Flight Management Computer).

567: (Q371) What happens if the pneumatic system bleed air is OFF, purposely or by failure?

- o A: a caution appears on the ECAM or EICAS screen.

- B: the OFF light in the control switch illuminates and a warning appears on the ECAM or EICAS screen.
- o C: the OFF light in the control switch illuminates and a memo appears on the ECAM or EICAS screen.

568: (Q42) Which movement can each individual blade of a semi-rigid rotor system make independently?

- o A: flap, change pitch and drag.
- o B: flap only.
- C: flap and change pitch.

569: (Q53) What is the benefit of using a semi-monocoque construction?

- o A: does not require rivetting.
- o B: no safety factor is required
- C: provides a stronger construction than a monocoque.

570: (Q307) Which component in a hydraulic system ensures immediate response when a service is selected?

- o A: engine driven pump.
- B: accumulator.
- o C: selector.

571: (Q208) To ensure correct operation of the emergency lighting system, what must be done at specific maintenance intervals?

- o A: Recharge the battery packs.
- B: Replace the battery pack.
- o C: Replace all emergency light bulbs.

572: (Q375) On an autopilot coupled approach, GO AROUND mode is engaged:

- o A: By the pilot selecting G.A. mode on the flight mode control panel.
- o B: If the aircraft reaches the decision height selected on the radio altimeter at a higher speed than the one selected.
- C: By the pilot pushing a button located on the throttles.

573: (Q381) The position of a Flight Director command bars:

- o A: only displays information relating to radio-electric deviation.
- B: indicates the manoeuvres to execute, to achieve or maintain a flight situation.
- o C: enables the measurement of deviation from a given position.

574: (Q374) An automatic pilot is a system which can ensure the functions of:

- o A: Piloting from take-off to landing without any action from the pilot.
- o B: Navigation.
- C: Piloting and guidance of an aircraft in both the horizontal and vertical planes.

575: (Q776) A ventilation fan has shut-down due to an overheat condition. The crew can....

- o A: restart the fan immediately by resetting the control switch to 'off' and 'on' again.
- o B: not restart the fan in flight. Ground crew must reset the system first.
- C: restart the fan after it has cooled down.

576: (Q453) Before an aeroplane is able to make an automatic landing the

- o A: ground radio aids must be at least CAT I.
- o B: ground radio aids must be at CAT II.
- C: ILS system must be working.

577: (Q359) The pressure regulator on an oxygen demand system regulates the pressure to:

- A: 70 PSI
- o B: 90 PSI
- o C: 400 PSI

578: (Q736) Airplane system data not critical to flight are connected to the..... In the Core Network System.

- o A: Crew Wireless LAN Unit (CWLU).
- o B: Common Data Network (CDN).
- C: Open Data Network (ODN).

579: (Q554) A yaw damper is....

- A: a rudder damper designed to avoid the "dutch roll".
- o B: an elevator augments.
- o C: an elevator augments to avoid nose-down effect at speeds greater than $M = 0.8$.

580: (Q682) WXR display is on:

- o A: the co-pilots screen only.
- B: on both the captains and co-pilots screens.
- o C: the captains screen only.

581: (Q751) Data from the In-Flight Entertainment system can be transferred to a terminal station on the ground

- o A: through an ethernet link when the aircraft is at the terminal.
- B: through a wireless GSM Cell Data Modem when the aircraft is at the terminal.
- o C: through an ethernet link when the aircraft is on the ground.

582: (Q215) Which of the following bleed air sources CANNOT supply the aircraft systems in flight?

- A: Pneumatic ground cart.
- o B: Engines.
- o C: Auxiliary power unit.

583: (Q506) MLS installations notified for operation, unless otherwise stated, provide azimuth coverage of....

- o A: +or - 20° about the nominal course line out to a range of 20 NM.
- B: +or - 40° about the nominal course line out to a range of 20 NM.
- o C: +or - 20° about the nominal course line out to a range of 30 NM.

584: (Q664) If an aircraft is flying (with flaps and landing gear retracted) in proximity to terrain and its GPWS (Ground Proximity Warning System) get activated, because it is detecting that the airplane has an excessive rate of descent, the system provides the following aural warning signals:

- o A: ... TOO LOW, TERRAIN ... (twice) followed by ... TOO LOW GEAR ... (twice).
- o B: ... TERRAIN, TERRAIN ... followed by ... WHOOP WHOOP PULL UP ... (twice).

- C: ...SINK RATE, SINK RATE ... followed by ... WHOOP WHOOP PULL UP ... (twice).

585: (Q657) Deviation compensation in a flux gate compass is done:

- o A: Automatically within the compass system.
- o B: Mechanically.
- C: Electronically.

586: (Q696) The input to a basic stall warning system is:

- o A: IAS.
- B: Angle of attack.
- o C: Slat/flap position.

587: (Q419) The purpose of an airplane automatic trim system is to trim out the hinge moment of the :

- A: elevator(s).
- o B: elevator(s) and rudder(s).
- o C: elevator(s), rudder(s) and ailerons.

588: (Q546) A Fowler flap....

- A: increases wing area.
- o B: decreases wing area.
- o C: does not change the wing area.

589: (Q181) The ram air turbine will supply....

- o A: DC power.
- B: single phase AC power.
- o C: three phase DC power.

590: (Q711) A FMS navigation database is updated

- A: every 28 days.
- o B: once a month.
- o C: at the operators request.

591: (Q280) What indicates the yellow disk of a fire bottle (if installed) when it is ruptured?

- A: That the bottle has been fired.
- o B: That the pressure in the fire bottle was too high.
- o C: That the fire bottle is due for inspection.

592: (Q709) Where is the loaded software held?

- A: CMC (Central Maintenance Computer) storage device, ready to be reinstalled should something happen that corrupts a particular program.
- o B: In a centralized maintenance cabinet, ready to be sent and reinstalled should something happen that corrupts a particular program.
- o C: On the flight deck, ready to be reinstalled should something happen that corrupts a particular program.

593: (Q777) The pilot receives an audible warning on the flight deck as the aircraft is descending to land. The most likely reason for this warning is ...

- A: the landing gear is not locked down.

- o B: the wheel speed is too high.
- o C: the brake temperature is too high.

594: (Q237) What determines the effective temperature of a cabin?

- o A: Temperature, humidity, thermal inertia and heat load.
- o B: Temperature only.
- C: Temperature and humidity.

595: (Q91) Which irregular variation in ionospheric conditions can cause a waiting period of several days before communications return to normal?

- o A: Sudden ionospheric disturbance.
- B: Ionospheric storms.
- o C: Sporadic E

596: (Q541) Which control surfaces may be used by active load control?

- A: Elevator and aileron.
- o B: Aileron and spoiler.
- o C: Elevator and stab.

597: (Q24) Aerodynamic speeds vary all the way from low subsonic to hypersonic. The limits of transonic speed range are

- A: 0.8 to 1.2 M
- o B: 1.2 to 5 M
- o C: 0.3 to 0.8 M

598: (Q701) In an engine vibration monitoring system for a turbojet any vibration produced by the engine is:

- o A: fed directly to the cockpit indicator without amplification or filtering.
- B: amplified and filtered before being fed to the cockpit indicator.
- o C: inversely proportional to engine speed.

599: (Q19) A wing slat is a movable airfoil attached to the leading edge of high-performance airplane wings. What is their purpose?

- o A: replace flaps.
- o B: act as a dive brake or speed brake.
- C: reduce stalling speed.

600: (Q124) The amplitude modulation and the colour of an outer marker (OM) is:

- o A: 400 Hz, amber.
- B: 400 Hz, blue.
- o C: 3000 Hz, amber.

601: (Q275) What does the red indicator disk on the fuselage indicate?

- o A: Indicates that the fire bottle has been fired.
- o B: Indicates that the fire bottle has not thermally discharged.
- C: Indicates a thermal discharged of the fire bottle.

602: (Q69) The relationship between the electric field and the magnetic field in a dipole or monopole antenna are....

- o A: in phase on a monopole and out of phase in a dipole.
- B: out of phase by 90°.
- o C: in phase.

603: (Q266) In a continuous loop fire detection system is the Kidde system a....

- o A: bi-metallic spot type.
- B: thermistor type.
- o C: pneumatic type.

604: (Q94) A transmission line is designed to perform which of the following functions?

- o A: Disperse energy in all directions.
- o B: Replace the antenna in a communications system.
- C: Guide electrical energy from point to point.

605: (Q138) A basic RNAV system will determine tracking information from....

- A: VOR/DME.
- o B: Twin VOR.
- o C: twin DME.

606: (Q694) The main input data to the Stall Warning Annunciator System are: 1. Mach Meter indication. 2. Angle of Attack. 3. Indicated Airspeed (IAS). 4. Aircraft configuration (Flaps/Slats). The combination regrouping all the correct statements is:

- o A: 2, 3.
- o B: 1, 2.
- C: 2, 4.

607: (Q311) What is the purpose of a 'cut-out' valve in a hydraulic system?

- o A: is to prevent creep in jack operated services which have several selected positions.
- B: is to relieve the pump of load when the operation of services is complete and the accumulator charged with fluid.
- o C: is to limit loss of fluid in the event of pipe fracture.

608: (Q288) What must be fitted to an automatic refueling system?

- A: protection against overflow.
- o B: fuel crossfeed system.
- o C: vents to allow overfueling.

609: (Q23) With respect to flight spoilers, when do they operate?

- o A: only operate in flight.
- o B: only operate on the ground.
- C: can operate both on the ground and in flight.

610: (Q423) The flare manoeuvre may be controlled by signals from

- o A: the glide slope receiver.
- B: radio altimeter.
- o C: the localiser receiver.

611: (Q547) Spoilers are speed brakes. Where can other speed brakes be located?

- o A: On the wing.
- o B: Under the Fuselage.
- C: Rear of the Fuselage.

612: (Q12) On an aircraft fitted with elevons in normal flight. What happens to the Elevons when the control column is moved forward?

- o A: remain stationary.
- B: both move down.
- o C: both move up.

613: (Q581) When an aircraft altimeter is set at 1013 mbar (29,92 inHg) on the ground, the altimeter will read

- o A: density altitude.
- B: pressure altitude.
- o C: calibrated altitude.

614: (Q755) Which unit lets the crew monitor and control the CSS (Cabin Services System)?

- o A: The PCU (Passenger Control Unit).
- o B: The SDU (Smart Display Unit).
- C: The CAP (Cabin Attendant Panel).

615: (Q636) The gyro mass is concentrated at its edge to....

- o A: increase its speed of rotation.
- B: increase its rigidity.
- o C: relieve bearing wear.

616: (Q411) An aircraft has yaw damping included in its auto stabilisation system. An essential requirement of such system is:

- o A: series connected servo motors.
- B: a three axis autopilot system.
- o C: INS inputs to the CADC.

617: (Q627) The indication of a fuel float gauge varies with: 1. Aircraft altitude. 2. Accelerations. 3. Atmospheric pressure. 4. Temperature. The combination of correct statement is:

- o A: 1, 2.
- o B: 1,2,3,4.
- C: 1,2,4.

618: (Q733) The ARINC 664 Ethernet has a transport rate of ...

- o A: 100 kilobits per second.
- B: 100 megabits per second.
- o C: 100 gigabits per second.

619: (Q607) An Air Data Computer (ADC):

- A: Transforms air data measurements into electric impulses driving servo motors in instruments.

o B: Is an auxiliary system that provides altitude information in the event that the static source is blocked.

o C: Measures position error in the static system and transmits this information to ATC to provide correct altitude reporting.

620: (Q135) What are the primary navigation inputs used by RNAV system?

• A: Nav Aids, INS, FMC.

o B: Nav Aids, Mapping Radar, FMC.

o C: INS, Nav Aids, TAS and Drift.

621: (Q524) Which system do you have to use if you want listen music in an aircraft?

o A: the VHF radio to the frequency of a local commercial FM radio station and then figure out how to couple it to the aircraft PA system.

• B: the ADF (Automatic Direction Finder) to the frequency of a local commercial AM radio station and then figure out how to couple it to the aircraft PA system.

o C: the VOR (VHF Omni Range) to the frequency of a local commercial FM radio station and then figure out how to couple it to the aircraft PA system.

622: (Q93) Under certain conditions, such as ducting, line-of-sight radio waves often propagate for distances far beyond their normal ranges because of which of the following factors?

o A: ionospheric storms.

o B: low cloud masses.

• C: temperature inversions.

623: (Q9) In normal flight, if the control wheel is moved to the left, what will the aileron on the right do?

o A: remain in the same position.

• B: move down.

o C: move up.

624: (Q624) A thermocouple can be made of:

o A: two metal conductors of the same nature fixed together at two points.

o B: a three wire coil.

• C: 'two metal conductors of different nature fixed together at two points.'

625: (Q392) With the autopilot engaged in the ALT mode the Captain alters the barometric setting. The aircraft:

o A: trips out of altitude hold.

• B: maintains its altitude.

o C: changes its altitude in accordance with the change in pressure setting.

626: (Q265) A carbon monoxide detector has to be replaced.....

• A: normally every 90 days.

o B: monthly.

o C: daily.

627: (Q279) Pushing the fire test button does not test:

o A: Fire detectors.

o B: Indications and warnings.

- C: Squibs.

628: (Q345) Aquaplaning can be reduced by ...

- A: an anti-skid device.
- o B: lowering slats.
- o C: increased flaring.

629: (Q156) Which of the following lists all the parameters that can be determined by a GPS receiver tracking signals from 4 different satellites?

- o A: Latitude, longitude and altitude.
- B: Latitude, longitude, altitude and time.
- o C: Latitude and longitude.

630: (Q291) How would you shut-off the low pressure fuel supply to the engine for the purpose of engine removal?

- o A: close the cross bleed valve.
- B: pull the fire shut-off handle.
- o C: close the HP fuel lock.

631: (Q385) An automatic flight control system:

- A: is another name for an autopilot system.
- o B: applies flight data to the auto pilot system.
- o C: can only be used in EFIS equipped aircraft.

632: (Q639) The acceleration errors of an electrically-driven attitude indicator are reduced compared to those of a vacuum driven one by:

- o A: spinning the electrical rotor slower.
- B: inclination of the gyro spin axis.
- o C: reducing the erection rate of the gyro assembly.

633: (Q326) Which system supplies air for anti-icing of the wings?

- A: engine compressors.
- o B: air conditioning ducting.
- o C: a combustion heater.

634: (Q699) When a stall warning occurs, the angle of attack vane....

- o A: moves aft.
- o B: moves down.
- C: moves up.

635: (Q328) How and when is windshield rain repellent applied?

- o A: before rain and spread on window surface by wipers.
- o B: rubbed on the surface of the windscreen, prior to flight.
- C: during rain and spread on windows surface by wipers.

636: (Q100) What is the wavelength of the basic Marconi antenna?

- o A: 1/2 wavelength.
- B: 1/4 wavelength.

o C: wavelength.

637: (Q548) Which device is used to dump lift?

- A: spoiler.
- o B: leading edge flaps.
- o C: trailing edge flaps.

638: (Q396) Overshoot or go-around mode can be initiated

- o A: at any time.
- o B: at any time after autoland has been engaged.
- C: only when the auto-approach mode is activated.

639: (Q354) Cabin chemical oxygen generators are located in?

- A: The passenger service units.
- o B: The overhead bins.
- o C: The cargo hold.

640: (Q253) After landing the outflow valve is set to release the remaining pressure....

- o A: full open at touchdown.
- o B: rapidly open.
- C: at a fixed rate.

641: (Q687) Alarms are standardized and follow a code of colors. Those requiring action but not immediately, are signaled by the color:

- o A: red.
- o B: flashing red.
- C: amber.

642: (Q195) Which of the following circuit breakers CANNOT be reset while the fault exists?

- A: Trip free circuit breaker.
- o B: Automatic reset circuit breaker.
- o C: Electromagnetic circuit breakers.

643: (Q175) The output sine waves of a 3-phase alternator will be separated by:

- A: 120 degrees
- o B: 60 degrees
- o C: 90 degrees

644: (Q692) The alerting system functional components used to accomplish the alerting and informing functions for warnings should include:

- A: master visual alert, and visual information and master aural alert.
- o B: master visual alert or visual information and master aural alert.
- o C: visual information, master aural alert and voice information.

645: (Q513) Hyperbolic propagation errors are....

- A: the greatest above land.
- o B: the greatest above water.
- o C: not present in this type of navigation.

646: (Q133) Bearing information in an ADF system is....

- o A: received by the antenna.
- B: measured and calculated by the ADF system.
- o C: provided by the flight management system.

647: (Q485) A false indication of water may be given by the AWR display when:

- A: flying over mountainous terrain.
- o B: flying over land with the Land/Sea switch in the Sea position.
- o C: there is cloud and precipitation between the aircraft and a cloud target.

648: (Q528) How are the IFES (In-Flight Entertainment System) Ethernet network set of units connected?

- o A: Infrared wires.
- o B: Glass fiber connection.
- C: Twisted pair wires.

649: (Q551) In which control system will an artificial feel system be required?

- o A: Power assisted control system.
- o B: Aerodynamically controlled system.
- C: Power operated control system.

650: (Q619) When climbing, the true airspeed....

- A: will increase with constant IAS.
- o B: remains the same.
- o C: will decrease with a constant IAS.

651: (Q602) The purpose of the altitude alert system is to generate a visual and aural warning to the pilot when the:

- o A: altimeter setting differs from the standard setting above the transition altitude.
- B: airplane altitude differs from a selected altitude.
- o C: proximity to the ground becomes dangerous.

652: (Q213) Where is the ground air conditioning cart used for?

- o A: Starting the engines.
- o B: Running the de-icing system.
- C: Supplying the cabin with conditioned air, when only the cabin needs to be conditioned.

653: (Q245) What is the function of the positive pressure relief valves?

- o A: They control cabin pressure and ensure the cabin altitude does not go above 10.000 ft.
- B: They relieve excess cabin pressure.
- o C: They prevent negative cabin pressure differential.

654: (Q557) When does a stick-shaker comes into operation? When the aircraft....

- A: is approaching a stall.
- o B: is approaching the 'critical mach number'.
- o C: goes supersonic.

655: (Q592) During descent, a blockage of the static source will cause the ASI to:

- o A: under-read.
- o B: either, depending on the attitude or configuration.
- C: over-read.

656: (Q695) The angle of attack transmitter provides an electric signal varying with: 1. the angular position of a wind vane. 2. the deviation between the airplane flight attitude and the path calculated by the inertial unit. 3. a probe differential pressure depending on the variation of the angle of attack. The combination regrouping all the correct statements is:

- o A: 2 and 3.
- o B: 1 and 2.
- C: 1 and 3.

657: (Q117) The Cockpit Voice Recorder of a large transport aircraft will always store the last....

- A: 30 minutes.
- o B: 120 minutes.
- o C: 60 minutes.

658: (Q52) In a monocoque structure, which component carries the majority of the loads?

- A: Skin.
- o B: Stringers.
- o C: Longerons.

659: (Q491) The data supplied by a radio altimeter:

- A: indicates the distance between the ground and the aircraft.
- o B: is used only by the radio altimeter indicator.
- o C: is used by the automatic pilot in the altitude hold mode.

660: (Q633) The degree of rigidity of a gyro depends on:

- o A: The rotor speed only.
- o B: The rotor weight only.
- C: The rotor speed and weight distribution.

661: (Q137) What is the required accuracy of a precision area navigation system?

- o A: 5 nautical miles.
- o B: 10 nautical miles.
- C: 1 nautical mile.

662: (Q84) Electrically charged particles that affect the propagation of radio waves are found in what atmospheric layer?

- A: Ionosphere.
- o B: Stratosphere.
- o C: Troposphere.

663: (Q414) A dual-dual stability augmentation system:

o A: ensures that a lane failure results in that the actuators remains at their position when the failure occurred.

- B: can survive the first failure and reverts to manual control in the event of a second failure.
- o C: disengages when a failure occurs and the system reverts to manual control.

664: (Q689) The level of alert for conditions that require immediate flight crew awareness and subsequent flight crew response is..... Engine overheat or low oil pressure are typical examples.

- o A: alert message.
- o B: a caution.
- C: a warning.

665: (Q585) As a result of a blocked static vent during a rapid climb, the VSI displays:

- A: zero rate of vertical speed.
- o B: an over-reading of the rate of climb.
- o C: the correct rate of climb.

666: (Q684) With an EFIS flight director using IRS guidance, reference north can be:

- o A: true north between 73°N and 65°S and magnetic north above these latitudes.
- o B: magnetic north only.
- C: magnetic north between 73°N and 65°S and true north above these latitudes.

667: (Q466) With localizer capture, the EFIS indication is VOR/LOC in....

- o A: white letters.
- B: green letters.
- o C: amber letters.

668: (Q90) The distance between the transmitter and the nearest point at which refracted waves return to earth is referred to as the

- o A: reception distance.
- o B: return distance.
- C: skip distance.

669: (Q45) Which control input must be used to lift the helicopter vertically into the hover?

- o A: collective pitch lever has to be lowered.
- o B: cyclic pitch lever has to be raised.
- C: collective pitch lever has to be raised.

670: (Q36) With an increase in its angle of attack, what happens to the drag acting on a rotor blade?

- A: increases.
- o B: decreases.
- o C: remains constant.

671: (Q589) The VSI-case is fed with ..(1)..... pressure and the capsule with ..(2)..... pressure.

- A: (1) static - (2) static
- o B: (1) pitot - (2) static
- o C: (1) static - (2) pitot

672: (Q488) Modern low altitude radio altimeters emit waves in the following frequency band:

- A: SHF (Super High Frequency).
- o B: UHF (Ultra High Frequency).
- o C: HF (High Frequency).

673: (Q121) ILS is subject to false glide paths resulting from:

- o A: false signals reflected by nearby obstacles.
- B: multiple lobes of radiation patterns in the vertical plane.
- o C: ground returns ahead of the antennas.

674: (Q141) The period of validity of the navigational database is:

- o A: 91 days.
- B: 28 days.
- o C: 1 month.

675: (Q431) The take-off of an aircraft is....

- o A: flown automatically.
- o B: not possible with go-around (GA) set on the trust mode control panel (TMCP).
- C: flown manually.

676: (Q289) How is fuel supplied to a turbine engine?

- o A: by a gravity feed pump.
- o B: by suction from the engine driven fuel pump.
- C: by a fuel boost pump.

677: (Q47) What happens when raising the collective lever?

- o A: the angle of attack is decreased on the retreating blade.
- o B: the pitch is decreased on all blades.
- C: the pitch is increased on all blades.

678: (Q662) The Ground Proximity Warning systems mode 4 is activated when

- o A: When the aircraft is significantly below its ILS glidepath.
- o B: An excessive height loss is experienced after take-off during go-around.
- C: An unsafe clearance situation is experienced, with the aircraft not in the landing configuration.

679: (Q727) Communication in the integrated modular avionics network is partly standardized in...

- A: ARINC 429, ARINC 653 or AFDX.
- o B: ARINC 429 or AFDX (Avionics Full Duplex).
- o C: ARINC 653 for the software avionics and AFDX for the data network bus.

680: (Q418) In the automatic trim control system of an autopilot, automatic trimming is normally effected about the :

- o A: pitch and roll axes only.
- o B: pitch, roll and yaw axes.
- C: pitch axis only.

681: (Q185) What type of voltage regulator is shown in the figure below?

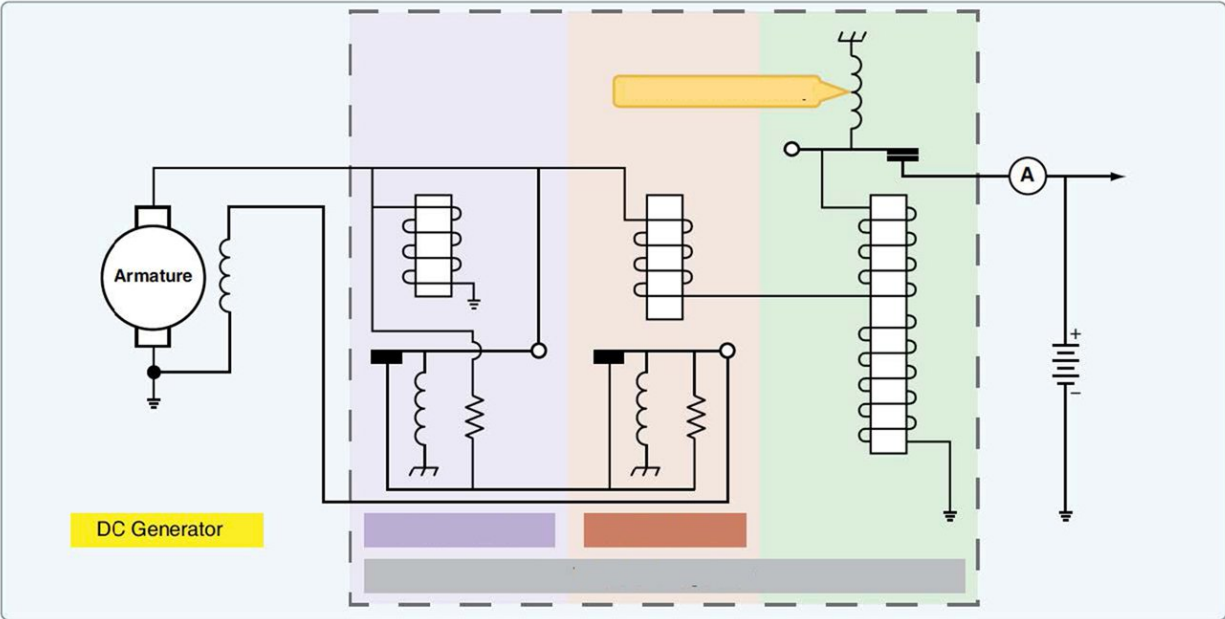

- o A: Reverse current delay.
- B: Three-unit voltage regulator.
- o C: Carbon pile voltage regulator.

682: (Q217) What is the purpose of the air conditioning system?

- o A: Increase the temperature of air and humidity.
- o B: Increase and decrease the temperature of air and pressurize the aircraft.
- C: Control the temperature, air flow and humidity.

683: (Q638) When turning (during 1 minute) through 90° at constant attitude and bank, a classic artificial horizon indicates:

- o A: Nose up and correct angle of bank.
- B: Nose up and bank angle too low.
- o C: Nose up and bank angle too high.

684: (Q187) Emergency lighting is part of which service?

- o A: Ground.
- o B: Essential.
- C: Vital.

685: (Q440) When can the FMS be engaged with the autothrottle?

- o A: With either the Flight Director or the Digital Control System (DFCS) engaged.
- B: only after take off.
- o C: only with the Flight Director selected.

686: (Q179) What powers the hydraulic motor generator (HMG)?

- A: Main hydraulic system.
- o B: RAT hydraulic pump.
- o C: Hydraulic hand pump.

687: (Q54) What are the main longitudinal members in a fuselage called?

- o A: spars.
- o B: frames.
- C: longerons.

688: (Q10) What is the main purpose of a Frise aileron?

- o A: Help pilot overcome aerodynamic loads.
- o B: Increase drag on the up going wing.
- C: Increase drag on the down going wing.

689: (Q535) What happens when you move the aileron control to the right?

- A: the right aileron moves down and the left up.
- o B: the right elevator goes up and the left down.
- o C: the right aileron moves up and the left down.

690: (Q142) When power is applied to the FMS, the CDU shows the....

- o A: climb (CLB) page for take-off.
- o B: route (RTE) page.
- C: ident page.

691: (Q174) If the over-speed protection circuit in a CSD (Constant Speed Drive) has activated, reset is....

- o A: possible from the flight deck.
- B: only possible in the workshop.
- o C: possible during Line Maintenance.

692: (Q231) A large aircraft air conditioning system's cabin temperature control....

- A: is selectable for each zone individually from the flight deck.
- o B: all zone temperatures are controlled from one master switch.
- o C: involves modulating the pack valve.

693: (Q26) Aerodynamic speeds vary all the way from low subsonic to hypersonic. The limits of high subsonic speed range are

- o A: 1.2 to 5 M
- o B: 0.8 to 1.2 M
- C: 0.3 to 0.8 M

694: (Q276) Which Halon type doesn't use a pressurisation agent?

- o A: Halon 1211.
- o B: Halon 1001.
- C: Halon 1301.

695: (Q65) What types of nuts must be used for bonding connections?

- o A: Nylon self locking nuts.
- B: Self locking nuts of all metal construction.
- o C: Nuts must not be used for bonding.

696: (Q21) When an aircraft fitted with spoilers is rolled to the left, what is the movement of the spoilers?

- o A: left upper spoiler up and left lower spoiler down.
- B: left spoiler is deflected up.
- o C: left spoiler is deflected up and the right down.

697: (Q511) A hyperbola is a line joining all points where the difference....

- A: of distance between two fixed points is the same.
- o B: in time between two fixed points is different.
- o C: of distance between two lines is different.

698: (Q429) LNAV is an ...(1)..... input to the.....(2)..... channel using data from the ...(3).....

- o A: (1) inner loop - (2) pitch - (3) ADC
- B: (1) outer loop - (2) roll - (3) FMC
- o C: (1) outer loop - (2) pitch - (3) FMC

699: (Q745) What is the primary control interface between the IFES (In Flight Entertainment System) and cabin and maintenance crews?

- A: The IFES CP (Crew Panel).
- o B: The IFES SC (system controller).
- o C: The IFES AMCU (Advanced Master Control Unit).

700: (Q88) What two layers in the ionosphere recombine and largely disappear at night?

- o A: F1 and F2
- B: D and E
- o C: D and F

701: (Q122) The aircraft DME receiver is able to accept replies to its own transmissions and reject replies to other aircraft interrogations because:

- o A: pulse pairs are amplitude modulated with the aircraft registration.
- B: pulse pairs are discreet to a particular aircraft.
- o C: transmission frequencies are 63 MHz different for each aircraft.

702: (Q726) What type of valve is the toilet tank drain valve?

- o A: Not spring loaded.
- B: Spring loaded closed.
- o C: Spring loaded open.

703: (Q360) When the N/100% selector is placed in the 'N' position on a diluter demand regulator, what is the oxygen flow supplied?

- o A: 100% oxygen while the user is inhaling.
- o B: A mixture of oxygen and cabin air at a constant flow.
- C: A mixture of oxygen and cabin air while the user is inhaling.

704: (Q95) A measurement of the voltage to current ratio (V_{in}/I_{in}) at the input end of a transmission line is called the

- A: input impedance.
- o B: voltage-gain ratio.
- o C: input-gain rate.

705: (Q27) Critical Mach Number (M_{crit}) is:

- o A: The Mach number at which shock waves are formed at the leading edge of the airfoil.
- B: The Mach number at which sonic flow is first achieved.
- o C: The Mach number at which compressibility effects first appear.

706: (Q450) Overshoot or go-around mode can be initiated....

- o A: only when autopilot is engaged.
- B: below 2000 feet radio altitude.
- o C: at any time.

707: (Q512) Hyperbolic navigation systems determine present position from the intersection of....

- o A: longitudinal magnetic field lines.
- B: lines of position.
- o C: GPS satellite intersection.

708: (Q230) What needs to be done to the bypass valve to lower the pack outlet temperature?

- A: Closed.
- o B: Opened.
- o C: Remain the same.

709: (Q183) How is voltage regulation achieved on DC generators? By changing the....

- A: field current.
- o B: generator speed.
- o C: field voltage.

710: (Q281) Does the pressure in a fire bottle vary with the temperature?

- o A: It has no influence on the pressure in a fire bottle.
- o B: Only when the temperature is lower than 10 degrees C.
- C: Yes.

711: (Q220) A refrigerant is used in....

- o A: a pneumatic pump.
- o B: an air cycle machine.
- C: a vapour cycle.

712: (Q325) An ice deposit formed when liquid water flows over the airframe before freezing, and which is dense, tough and sticks closely to the surface is called ...

- A: glaze ice.
- o B: rime ice.
- o C: hoar frost.

713: (Q255) The emergency pressure control valve....

- A: is not a very refined way of controlling.
- o B: is fitted to all pressurized aircraft.
- o C: is electrically controlled.

714: (Q544) What will an extended fowler flap increase?

- o A: Wing area.

- o B: Wing area and aspect ratio.
- C: Wing area and camber.

715: (Q59) Which system is used to determine precise points located on an aircraft?

- o A: frame stations, vertical lines and lateral lines.
- o B: longitudinal, vertical and lateral lines.
- C: frame stations, water lines and buttock lines.

716: (Q626) In transport category airplanes, the temperatures are generally measured with: 1. resistance thermometers. 2. thermocouple thermometers. 3. reactance thermometers. 4. capacitance thermometers. 5. mercury thermometers. The combination regrouping all the correct statements is:

- o A: 1,3,4,5
- o B: 1,2,5
- C: 1, 2.

717: (Q621) The white sector of the arc of a temperature gauge corresponds to:

- o A: an exceptional operating range.
- B: a normal operating range.
- o C: a special operating range.

718: (Q768) On which system are scheduled maintenance tasks shown when a time or cycle limit occurs in an airplane system?

- A: on the multifunction displays, the electronic flight bags and the maintenance laptop.
- o B: on the maintenance laptop and the electronic flight bags.
- o C: only on the maintenance laptop.

719: (Q263) In a dual loop fire detection system. 'Loop A' fire warning is shown, this means:

- o A: Loop A has detected a fire and loop B is faulty.
- o B: Loop a is faulty.
- C: A fire test must be performed to determine the condition of the loops.

720: (Q532) In a Frise aileron control system....

- o A: the up-going aileron moves through a greater angle than the down going aileron.
- o B: the down-going aileron leading edge protrudes into the airflow.
- C: the up-going aileron produces increased drag.

721: (Q60) Water Lines (WLs) are measured points on a

- A: vertical line.
- o B: wing line.
- o C: horizontal line.

722: (Q673) The Flight Data Recorder actually starts running:

- A: before the a/c starts moving under its own power.
- o B: when a/c lines up on runway.
- o C: at the beginning of the T/O run.

723: (Q653) The directional gyro keeps its rotation axis aligned toward:

- o A: Magnetic North.
- B: A point in space.
- o C: Geographic North.

724: (Q250) In a modern electronic pressurization system, what happens if the automatic cabin pressure controller fails?

- A: The crew has to control the cabin pressure manually.
- o B: The pressurization system is inoperable and the aircraft must descend to a lower altitude.
- o C: The standby cabin pressure controller takes over.

725: (Q287) On Large transport aircraft fuel is delivered to each engine using ...

- o A: a parallel system.
- o B: the same system for each engine.
- C: a separate system for each engine.

726: (Q192) Transformer rectifiers are used for:

- A: Converting AC into DC.
- o B: Converting DC into AC.
- o C: Boosting the output voltage from 28V to 110V.

727: (Q368) What type of air pump is commonly used in low pressure pneumatic systems?

- o A: Centrifugal pump.
- B: Vane pump.
- o C: Piston pump.

728: (Q649) The rotor of a rate gyroscope is over speeding. The pilot carries out a turn with the rate gyroscope indicating RATE 1. The actual rate of turn will be:

- o A: more than 3° per second.
- B: less than 3° per second.
- o C: 3° per second.

729: (Q676) What does a FDR record when combined with a CVR? 1. Cockpit voice; 2. Radio; 3. Public addresses from the cockpit; 4. Cabin voice

- o A: all 4.
- B: 1, 2 and 3.
- o C: 2 and 4.

730: (Q487) A radio altimeter can be defined as a....

- A: self-contained on-board aid used to measure the true height of the aircraft.
- o B: ground radio aid used to measure the true altitude of the aircraft.
- o C: self-contained on-board aid used to calculate the barometric altitude of the aircraft.

731: (Q31) The angle of attack of a blade is the

- A: angle between the chord line and relative airflow.
- o B: angle between the chord line and plane of rotation.
- o C: angle between the aircraft longitudinal axis and relative air flow.

732: (Q193) What provides overheat warning in a transformer rectifier unit?

- o A: Thermocouple.
- o B: Voltage sensor.
- C: Thermal switch.

733: (Q456) Purpose of an autoland decrabbing manoeuvre is to

- o A: assist with glide slope tracking.
- B: point the aircraft down the runway at touch down.
- o C: assist with localiser tracking.

734: (Q748) Each Ethernet station is given a 48-bit address. How are the first two fields called?

- o A: Parity Bit.
- o B: Country Code.
- C: Source/destination Identifier (SDI).

735: (Q343) When the landing gear is selected up the sequence of lights is....

- A: green, red, out.
- o B: red, green, out.
- o C: out, red, green.

736: (Q299) Pressure refuelling is carried out at....

- o A: 100 PSI.
- o B: 20 PSI.
- C: 40 PSI.

737: (Q316) Where is the high pressure filter in a hydraulic system fitted?

- o A: downstream of the reservoir.
- B: downstream of the pump.
- o C: in the return line to the reservoir.

738: (Q178) In a constant speed motor generator, what powers the generator?

- A: A hydraulic motor powered by a hydraulic pump driven by the RAT.
- o B: An electric motor powered by the battery.
- o C: An electric motor powered by the RAT generator.

739: (Q79) Which of the following statements about a wave is the law of reflection?

- A: The angle of incidence is equal to the angle of reflection.
- o B: The angle of incidence is equal to the refracted wave.
- o C: The angle of incidence is not equal to the refracted wave.

740: (Q285) What kind of data do we find on the labels of a portable fire extinguisher?

• A: The manufacturer name and P/N & S/N. Approval date and instructions to use. Extinguisher type, weight details and last check or expire date. In the bottle usually the manufacturers date is engraved.

o B: The manufacturer name. P/N & S/N. The colour will say the type (green=water, red=halon). The press indicator will show if the bottle is filled to level.

o C: The manufacturer and approval date and instructions to use.

741: (Q623) A thermocouple type thermometer consists of....

- o A: two metal conductors of the same type connected at two points.
- o B: a Wheatstone bridge connected to a voltage indicator.
- C: two metal conductors of different type welded together at one point.

742: (Q188) What type of bus is show in the figure below?

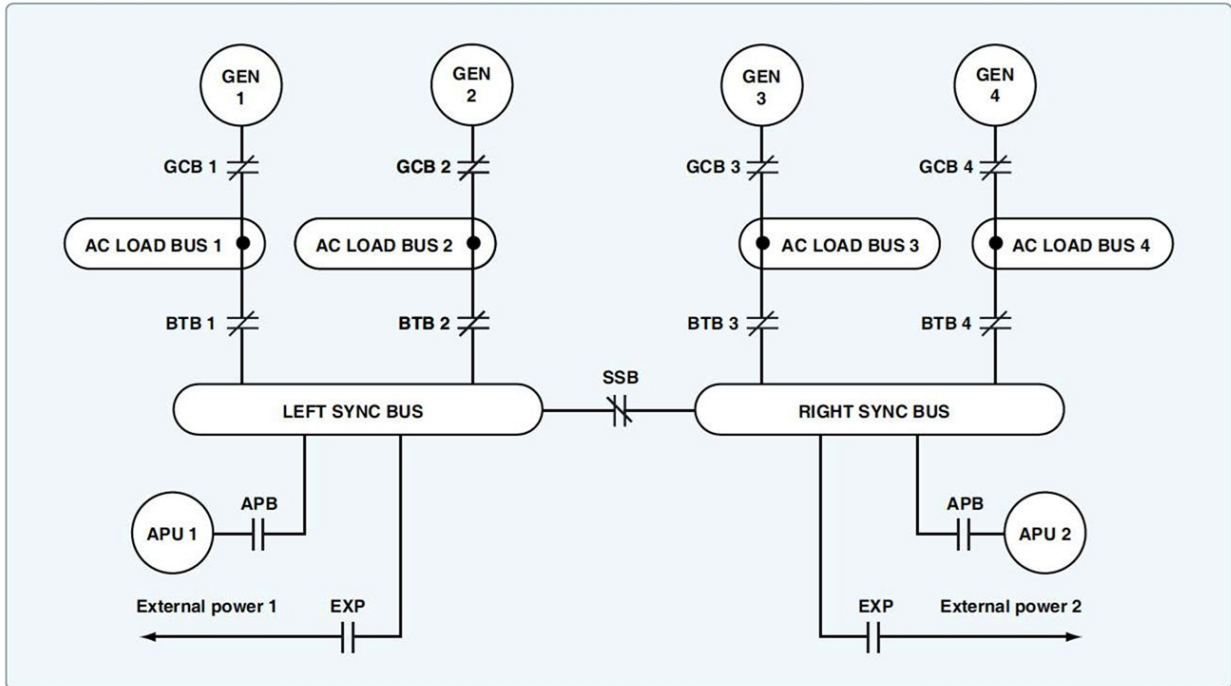

- o A: Emergency bus
- B: Split Parallel Bus
- o C: Parallel bus

743: (Q347) Why is a hydraulic damper fitted to a nose wheel steering system?

- o A: to centralise the nose wheel during an up selection.
- B: to reduce vibration and shimmy.
- o C: To centralise the nose leg assembly during an up selection.

744: (Q256) How is the emergency pressure control valve operated if the automatic control system fails?

- A: Manually
- o B: Electrically
- o C: Hydraulically

745: (Q28) Above the critical Mach number, the drag coefficient

- o A: remains the same.
- o B: decreases.
- C: increases.

746: (Q754) Which unit gathers information for proximity sensors to determine the flight phase and sends discrettes to the System Controller to provide it with flight phase information for the passengers?

- A: The PSEU (Proximity Switch Electronics Unit).
- o B: The FMS (Flight Management System).

o C: The INS (Inertial Navigation System) or IRS (Inertial Reference system).

747: (Q17) When a Leading edge flap is fully extended, what is the slot in the wing for?

- o A: To increase the lift.
- o B: To allow the flap to retract into it when it retracts.
- C: To re-energise the boundary layer.

748: (Q296) Cross feed valves permit fuel transfer from ...

- A: any tank to any engine.
- o B: left tank to right tank.
- o C: tank to tank.

749: (Q539) The purpose of a trim tab (device) is to....

- o A: trim the airplane at low airspeed.
- B: reduce or to cancel control forces.
- o C: to assist in steering commands.

750: (Q247) During take-off the outflow valve is selected to

- o A: modulating mode.
- B: fully open.
- o C: fully closed.

751: (Q261) What type of smoke detector contains radioactive material?

- A: Ionizing smoke detectors.
- o B: Carbon monoxide detectors.
- o C: Photo-electric smoke detectors.

752: (Q37) What will the advancing blade do during forward flight?

- o A: lag.
- o B: flap down.
- C: flap up.

753: (Q22) To which flight control are wing spoilers, when used asymmetrically, associated?

- A: ailerons.
- o B: rudder.
- o C: elevators.

754: (Q635) Increasing the angular momentum of a gyro rotor will:

- o A: have no substantial effect on gyroscopic rigidity.
- o B: decrease the gyroscopic rigidity.
- C: increase the gyroscopic rigidity.

755: (Q367) What is used to prevent moisture from freezing as the pressure drops in a pneumatic system?

- A: A water separator and a desiccant is fitted which collects the moisture from the air.
- o B: There is no water or moisture in compressed air.
- o C: An electrical heater is fitted which prevents the water from freezing.

756: (Q693) A stall warning system is based on a measure of:

- A: angle of airflow sensor and flap position transmitter.
- o B: Airspeed.
- o C: Groundspeed.

757: (Q637) Using a classic Artificial horizon, the aircraft performs a right turn (during 1 minute) through 270° at a constant angle of bank and rate of turn. The indication is:

- o A: Nose up, not enough bank.
- o B: Bank and pitch correct.
- C: Nose up, too much bank.

758: (Q3) When the control column is moved forward and to the right, what is the reaction of the flight control surfaces?

- o A: the elevator goes up, the right aileron moves up and the left aileron moves down.
- B: the elevator goes down, the right aileron moves up and the left aileron moves down.
- o C: the elevator goes down, the right aileron moves down and the left aileron moves up.

759: (Q553) An artificial feel system is required for....

- o A: power assisted control systems.
- o B: direct cable systems.
- C: power operated control systems.

760: (Q7) How can adverse yaw when rolling about the longitudinal axis be prevented?

- o A: a smaller fin.
- B: differential ailerons.
- o C: equal deflection lateral control surfaces.

761: (Q15) What do ruddervators do?

- A: control pitch and yaw.
- o B: control yaw and roll.
- o C: control pitch and roll.

762: (Q372) How is pneumatic leak detection done?

- o A: Thermal switches.
- B: Pressure sensors.
- o C: Thermocouples.

763: (Q563) The rate-of-turn is the:

- o A: yaw rate in a turn.
- B: change-of-heading rate of the aircraft.
- o C: aircraft speed in a turn.

764: (Q507) Which one of the following methods is used by a Microwave Landing System (MLS) to indicate distance from the runway threshold?

- o A: Measurement of the frequency shift between the MLS azimuth and elevation transmissions.
- B: A DME co-located with the MLS transmitters.
- o C: Timing the interval between the reception of sequential secondary radar pulses from the MLS station to the aircraft.

765: (Q38) What prevents the rotor blades from 'folding up' during rotation?

- o A: the weight.
- B: the centrifugal force.
- o C: the lift force.

766: (Q205) Which lights are located in the passenger service units?

- A: Spotlights.
- o B: Cabin emergency lights.
- o C: Flood lights.

767: (Q116) The Cockpit Voice Recorder (CVR) records : 1. conversations between pilot and co-pilot. 2. conversations between cockpit crew and air traffic controllers. 3. passenger announcements. 4. ambient cockpit sounds for example deployment of the landing gear.

- o A: only 1 and 2.
- B: 1, 2, 3 and 4.
- o C: 1, 2 and 3.

768: (Q582) In the next figure of a servo altimeter the components labeled A, B and C in order are:

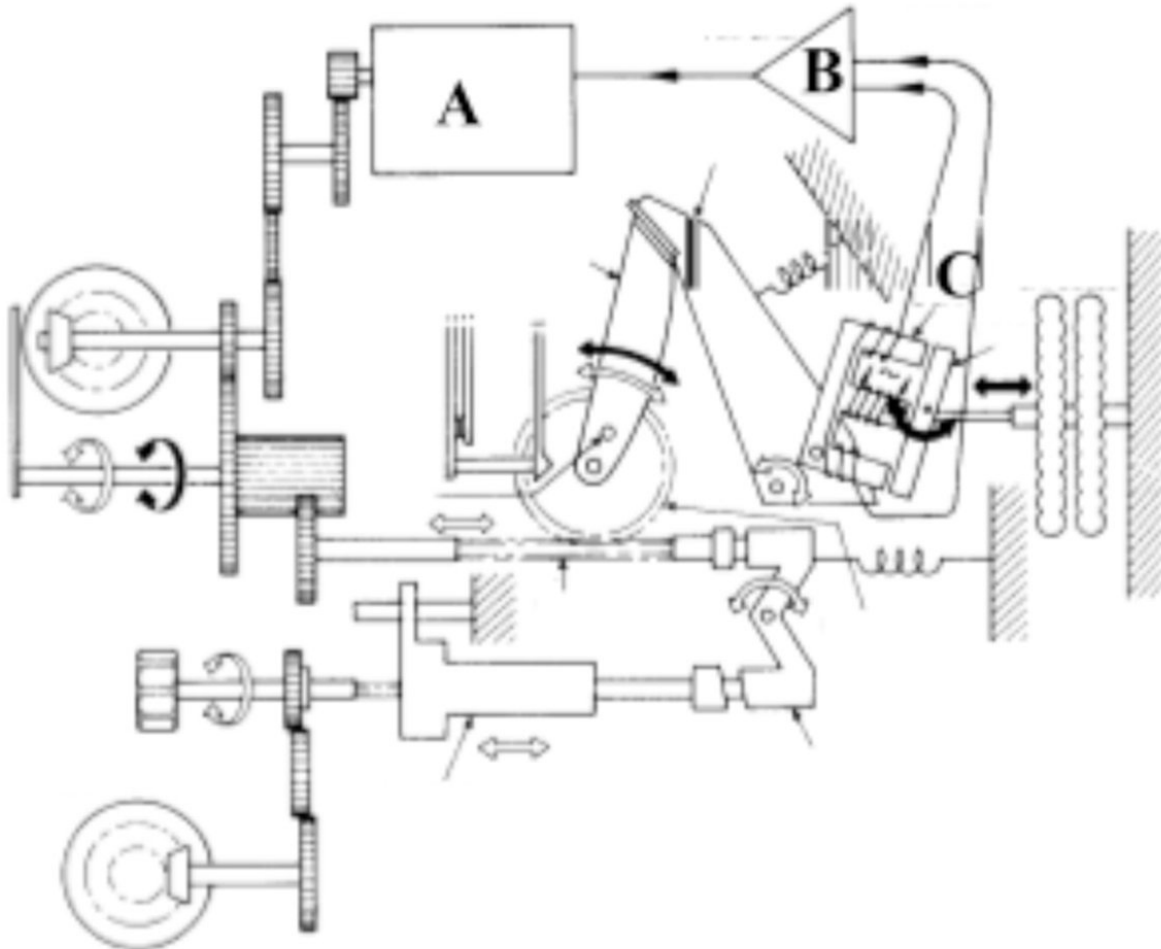

- A: two way motor - amplifier - inductive pick-off

- o B: torque motor - amplifier - transducer
- o C: torque motor - inductive pick-off - amplifier

769: (Q579) If the static source to an altimeter becomes blocked during a descent, the instrument:

- o A: Will progressively under-read.
- B: Continues to show the height at which the blockage occurred.
- o C: Will over-read by a constant amount.

770: (109) The HFmatches the antenna impedance to the transceiver output over the HF frequency range.

- o A: FDAU (Flight data acquisition unit)
- o B: transceiver
- C: antenna coupler

771: (Q471) On a TCAS2 (Traffic Collision Avoidance System) the preventive 'resolution advisory' (RA)....

- o A: advises the pilot to modify effectively the vertical speed of his aircraft.
- B: suggests action to be taken to avoid a conflict.
- o C: advises the pilot to modify the speed of his aircraft.

772: (Q336) What is the function of a fusible plug in an aircraft wheel rim?

- o A: As overpressure protection.
- B: As overtemperature protection.
- o C: To deflate the tyre before removal.

773: (Q587) The function of the accelerometer in the IVSI is....

- A: to give immediate response to vertical departures from horizontal flight.
- o B: to enable the instrument to be used at bank angles in excess of 40°.
- o C: to damp' the system during rapid alternating height changes.

774: (Q412) A triplex system loses one channel, the pilot....

- A: can continue with autoland.
- o B: must make a full manual approach and land.
- o C: can use auto approach only.

775: (Q163) What happens at the end of the charge of a NiCad battery?

- o A: CO2 is generated,
- o B: The battery heats up.
- C: The cell voltage drops.

776: (Q338) The cam plate in a nose undercarriage is ...

- o A: part of the shimmy damper.
- B: to centre the nose wheels for gear retraction.
- o C: for alignment of the nose wheel steering on nose undercarriage extension.

777: (Q76) A stone dropped into water creates a series of expanding circles on the surface of the water. This is an example of which of the following types of wave motion?

- A: Transverse.
- o B: Longitudinal.

o C: Concentric.

778: (Q284) When should you use halon-type portable fire extinguishers? The halon-type portable fire extinguisher may be used....

o A: only for fuel fires. (All fuel types)

o B: on solid materials combustible materials only.

• C: for every kind of fire. In the cabin it will be used for fires coming from electrical equipment.